

Rotavirus vaccines and vaccination in Latin America

Alexandre C. Linhares¹ and Joseph S. Bresee²

ABSTRACT

Worldwide, rotaviruses account for more than 125 million cases of infantile gastroenteritis and nearly 1 million deaths per year, mainly in developing countries. Rather than other control measures, vaccination is most likely to have a major impact on rotavirus disease incidence. The peak incidence of rotavirus diarrhea occurs between 6 and 24 months of age. In developing countries, however, cases are not uncommon among children younger than 6 months. G serotypes 1 to 4 are responsible for most disease, but there are indications that in Brazil that G type 5 is of emerging epidemiological importance. Both homotypic and heterotypic responses are elicited during natural rotavirus infection, and the immunological response at the intestinal mucosal surface is probably the more consistent predictor of clinical immunity.

With the primary objective of protecting children against life-threatening dehydrating diarrhea, many approaches to rotavirus vaccine development have been attempted. One vaccine, the tetravalent rhesus-human reassortant rotavirus vaccine (RRV-TV), was given licensing approval in the United States of America, introduced to the market, and later withdrawn.

A number of studies have found better efficacy of RRV-TV in developed countries than in developing ones. Field trials with a 4×10^4 plaque-forming units (PFU) preparation of RRV-TV have been carried out in two countries in Latin America, Brazil and Peru. Those trials yielded protective efficacy rates against all rotavirus diarrhea ranging from 18% to 35%. Data from a large catchment trial in Venezuela with a higher RRV-TV dose, of 4×10^5 PFU/dose, indicated an efficacy rate of 48% against all rotavirus diarrhea and 88% against severe rotavirus diarrhea. It appears that breast-feeding does not compromise the efficacy of RRV-TV if three doses of the vaccine are administered. Similarly, possible interference of oral poliovirus vaccine with the "take" of the rotavirus vaccine can be overcome by giving three doses of the rotavirus vaccine or by using a higher-titer formulation of it. Wild enteroviruses, however, may cause primary rotavirus vaccine failure in developing countries. Studies in Peru with RRV-TV have shown a trend towards higher vaccine efficacy rates against "pure" (rotavirus-only) diarrheal episodes. Economic analyses made in the United States indicate that a vaccine that costs less than US\$ 9 per dose would lead to a net savings in medical costs. To date, however, cost-benefit studies have not been done in developing countries. In the future, it is possible that some Latin American countries might adapt their polio production facilities to the preparation of rotavirus vaccines for human use.

A year after RRV-TV was licensed for vaccination of infants in the United States, the occurrence of intussusception as an adverse event led to the vaccine's withdrawal from the market. The implications of that action, particularly for Latin America, will be addressed in this article, including the need to explore alternative rotavirus candidate vaccines, particularly through the conduct of parallel clinical trials in both developed and developing countries.

¹ Fundação Nacional de Saúde, Instituto Evandro Chagas, Virology Section, Belém, Pará, Brasil; Send correspondence to: Alexandre C. Linhares, Fundação Nacional de Saúde, Instituto Evandro Cha-

gas, Virology Section, Av. Almirante Barroso, 492, 66.090-000, Belém, Pará, Brasil; telephone: (091) 2114403; fax: (091) 2261284; e-mail: linhares@supridad.com.br

² United States, Centers for Disease Control and Prevention, Division of Viral and Rickettsial Diseases, Respiratory and Enteric Virus Branch, Atlanta, Georgia, United States of America.

Acute gastroenteritis is a leading cause of morbidity and mortality in infancy and childhood throughout the world, especially in developing countries. Each year diarrheal diseases cause 744 million to one billion cases of diarrhea in Africa, Asia, and Latin America in children under 5 years of age. Of these children, it is estimated that 2.4–3.3 million of them die per year, corresponding to some 6 600 to 9 000 deaths per day (1–3). An additional hazard in developing countries is that malnutrition makes children more prone to severe disease and, conversely, repeated episodes of diarrhea may lead to malnutrition (1).

In Latin America the incidence rates of diarrheal disease among infants and young children vary widely between different regions and localities, according to prospective community-based studies (1). In the poorest periurban communities of Peru and Brazil, the average annual number of diarrheal episodes per child under 2 years of age reaches 10 or more, while the incidence rate may be as low as 0.7 per child per year among infants (0–1 year old) in Costa Rica (4–7).

Estimates for mortality indicate that the annual number of deaths caused by diarrhea among infants less than 1 year of age also varies widely from region to region, ranging from 4.5 per 1 000 live births to 21.8 per 1 000 (8, 9). Nevertheless, data that the Pan American Health Organization (PAHO) gathered from 21 countries indicate that the overall mortality from diarrheal disease in Latin America has declined considerably over the past two decades (10–12). Worldwide observations suggest that several factors may have contributed to this reduction, such as instruction in the correct case management of acute watery diarrhea, particularly at health care centers; the encouragement of breast-feeding; and improvements in measles immunization coverage (1, 13, 14).

During these past two decades, the spectrum of enteropathogens known to cause diarrhea has increased, primarily through the identification of a number of novel viral agents, such

as rotaviruses, enteric adenoviruses, astroviruses, and Norwalk and/or antigenically related agents (15). It has been estimated that viral agents account for a minimum of 30% of documented cases of infectious diarrhea in the United States of America (16).

Since their first detection by Bishop et al. (17) in Melbourne, Australia, rotaviruses have been clearly established as the most common cause of severe, dehydrating gastroenteritis in infants and young children in both industrialized and developing countries (18, 19). It has been estimated that rotaviruses each year worldwide are associated with more than 125 million cases of infantile gastroenteritis and cause a minimum of 418 000 to 520 000 deaths, 85% of which occur in low-income countries (20, 21). An effective vaccine could prevent as many as 326 000 of these deaths each year (20, 21).

The similar incidence of the illness in both industrialized and developing countries suggests that the problem will not be controlled by merely improving the water supply, sanitation, or hygiene practices, and that an effective vaccine is required (22, 23). De Zoysa and Feachem (22) calculated that the administration of an effective rotavirus vaccine within the first 6 months of life might prevent at least 16% of the diarrhea deaths that occur among children under 5 years of age. These figures fully justify current global efforts directed towards the development of a vaccine targeted for use in early childhood. Rather than preventing rotavirus infection or mild illness, the primary goal of rotavirus vaccine strategies would be to protect against severe diarrhea that might lead to dehydration and death.

This review will focus mainly on the current status of rotavirus candidate vaccines and the prospect of their future use in public health programs in Latin America, including as a result of the introduction of one rotavirus vaccine to the market and its subsequent withdrawal following the occurrence of intussusception among some vaccinated infants. To provide background for the main subject of this report we

will briefly discuss available information on rotavirus structure and antigenic composition, epidemiology, and immunity. We will especially emphasize the epidemiological features of rotavirus infection in Latin American countries.

GENERAL INFORMATION ON ROTAVIRUS INFECTION

Structure and antigenic characterization

The rotaviruses are classified within a specific genus of the family Reoviridae. The complete virus particle is often described as smooth, measures about 70 nm in diameter, and is composed of three protein shells surrounding the genome. This triple-layered structure possesses capsomeres radiating from the inner to the outer capsid, like the spokes of a wheel (*rota*, Latin for wheel) (24). Incomplete (or rough) "single-shelled" particles lacking the outer capsid are also commonly found in stool samples and tissue culture supernatants. The viral genome, located within the core, consists of double-stranded RNA that can be separated by gel electrophoresis into 11 discrete segments, or genes. Each of these genes encodes a single protein, except gene 11, which seems to encode two distinct polypeptides (25). The outermost layer of the double capsid is composed of two surface proteins, VP7 and VP4. VP7 is a glycoprotein coded by gene 7, 8, or 9, and VP4 is a protease-dependent protein coded by gene 4. These two surface proteins independently induce neutralizing antibodies (19, 26, 27). Specific antibody response to these proteins has been demonstrated after natural rotavirus infection (28) and also following administration of candidate vaccines of animal origin (29).

Of particular interest is sero-response to VP4 following the natural infection of humans. That is because antibodies to this protein are known to broadly react across different serotypes (30, 31). Cryoelectron micro-

scopy studies using computer-assisted image enhancement have shown that VP4 forms 60 spikelike structures that protrude more than 10 nm from the viral surface (32, 33). VP4 is the viral hemagglutinin and appears to have a role in viral virulence (15, 34). The cleavage of VP4 by pancreatic trypsin into VP5* and VP8* subunit proteins initiates the process of viral penetration into host cells (35).

VP7 makes up 90% of the smooth outer capsid surface, which is perforated by 132 channels penetrating the virion and reaching the viral core. The inner shell consists of trimerized VP6 (coded by gene 6), which makes up over 51% of the virion (19). The core is composed of VP1, VP2, and VP3 proteins, coded by genes 1, 2, and 3, respectively. In addition to the six structural proteins, five nonstructural polypeptides (NSP1 through NSP5) have been identified as being encoded by each of the five remaining rotavirus genes (36). Interesting recent studies (37, 38) have provided evidence that NSP4 may cause secretory diarrhea, thus acting in a similar way to that of the heat-labile enterotoxin of *Escherichia coli*. It is likely that NSP4 will be a target for future rotavirus vaccine strategies.

Three major antigenic specificities are assigned to rotaviruses: group, subgroup, and serotype. Both group and subgroup specificities are mediated mainly by VP6, which is the major inner capsid protein. To date, seven groups—designated as A, B, C, D, E, F, and G—have been distinguished in humans, other mammals, and birds. Only group A, however, contains rotavirus strains of epidemiological importance, and a vaccine should primarily confer protection to infants and young children against serious illness caused by this group (36). Two subgroups, I and II, can be identified within group A, as determined by monoclonal antibodies (39). The classification of rotaviruses in serotypes is based on both glycoprotein VP7 (“G” types) and protease-sensitive protein VP4 (“P” types) antigenic specificities. Although 14 rotavirus G types have been identified to date,

serotypes 1 through 4 are recognized to be globally most common. However, other serotypes may be common in specific countries (15, 19, 40). In general, all human subgroup I rotaviruses bear the G serotype 2 specificity, whereas subgroup II strains may belong to G serotypes 1, 3, and 4. There are at least 11 distinct VP4 (P) serotypes. Of these 11, 6 of them have been identified among the human rotaviruses: 1, 2, 3, 4, 5, and 11; these include four subtypes (36, 41). Recent nucleotide and amino acid sequence analyses, on the other hand, allowed the identification of six distinct rotavirus VP4 genotypes in humans, designated as P[4], P[6], P[8], P[9], P[10], and P[12]. It has been established that human rotavirus of P genotypes 4, 6, 8, and 9 correspond to P serotypes 1B, 2A, 1A, and 3, respectively (42).

Surveys of rotavirus P types in hundreds of fecal specimens from seven countries revealed that types P1A[8] and P1B[4] are the most common among the rotaviruses of human origin (42–44). In the light of the currently adopted binary system (VP7 and VP4 type specificities) for classification of rotavirus strains (40), it is known that three of the four epidemiologically important G serotypes (1, 3, and 4) possess P type 1A[8] specificity, while G2 has P1B[4] specificity (42). However, in recently established countrywide surveillance in the United States, nearly 10% of rotavirus strains were found to bear unusual P- and G-type specificities (45). In summary, although the total number of distinct G and P types is large, the vast majority of them fall into four G types and two P types.

Epidemiology and pathogenesis

Globally, group A rotaviruses are generally recognized as the most common enteropathogens identified among infants and young children hospitalized with dehydrating diarrhea. In both developed and developing countries it is estimated that 12% to 71% (median, 34%) of the severe di-

arrheal episodes occurring in this age group are associated with group A rotaviruses (15, 18, 19). Groups B and C, which are antigenically and genetically distinct, also infect humans. Group B has been associated with extensive epidemics of diarrheal illnesses, primarily among adults in China (46, 47). Group C viruses, on the other hand, are primarily swine pathogens and appear to cause infrequent and sporadic diarrheal disease among children in many parts of the world. One recent study has shown that group C rotavirus may be associated with extrahepatic biliary atresia among infants (48), and other studies have associated the group with foodborne institutional outbreaks of gastroenteritis (49, 50).

Fecal-oral transmission is the most likely route of rotavirus spread, but some limited evidence suggests that respiratory transmission might also occur. While an infected, diarrheic person may excrete approximately one trillion infectious particles per milliliter of stool, the infective dose in a child can be as little as 10 particles (51). The main site of viral multiplication is the mature enterocytes on the villi of the upper small intestine. Over a period of 1–2 days infection spreads from the proximal small bowel to the ileum. Histopathological studies in animal models have shown mild villus shortening, crypt hyperplasia, mitochondrial swelling, and infiltration of the lamina propria with mononuclear cells (19, 52). The major mechanism for diarrheal disease induction in rotavirus infection is likely to be decreased absorption of salt and water, as a result of intestinal damage and replacement of absorptive epithelial cells by secreting cells from the villous crypts (53). An additional possible mechanism is related to the depressed levels of disaccharidases, leading to carbohydrate malabsorption and osmotic diarrhea (15, 54). Finally, recent studies have shown that diarrhea may occur in the absence of epithelial lesion demonstrable by light microscopy, thus raising the question as to whether other mechanisms might be

involved in the induction of rotavirus gastroenteritis (55). In this respect, it is worth noting the findings of Ball et al. (37), which provide evidence that NSP4—a nonstructural rotavirus protein coded by gene 10—may act as an enterotoxin in a murine model, inducing secretory diarrhea. In addition, and of interest for vaccine strategies, these authors have demonstrated that antibodies to NSP4 protect against disease. It has recently been hypothesized that rotaviruses evoke intestinal fluid and electrolyte secretion by activation of the enteric nervous system (56).

It has been reported, from longitudinal studies conducted in several countries, that asymptomatic rotavirus infection is frequent and accounts for up to 80% of cases (57–59). On the other hand, rotavirus illness is preceded by an incubation period of 24 to 48 hours, has an acute onset, and usually lasts 5 to 7 days. The clinical picture includes vomiting, which starts early in the course of disease, as well as fever, watery diarrhea, mild to moderate dehydration, and abdominal pain. Both vomiting and fever remit within the first 2 to 3 days of illness, while diarrhea usually persists for 5 to 8 days. In general, laboratory tests indicate normal serum sodium concentration, mild to moderate elevation of blood urea nitrogen, and mild metabolic acidosis (60, 61). Treatment of rotavirus diarrhea is mainly symptomatic and includes oral (or, less frequently, intravenous) replacement of fluid and electrolytes in order to correct dehydration (62). Of public health importance is the fact that rotavirus diarrhea has been associated with the development of lactose intolerance, resulting in a protracted course of diarrhea and exacerbating existing protein-calorie malnutrition among infants and young children living in tropical regions (23, 63).

As previously stressed, the burden of rotavirus disease in both developed and developing countries is staggering, particularly among young children aged less than 2 years old (20). While rates of morbidity related to ro-

tavirus diarrhea are similar in both industrialized and developing countries, the disease is often severe and fatal among infants and young children living in the latter regions, where malnutrition may be an additional hazard (19, 23). Regardless of socioeconomic status or environmental conditions, it has been reported that, worldwide, over 90% of children at the end of the third year of life have acquired rotavirus antibody (19, 64). Most studies indicate that the peak incidence of rotavirus gastroenteritis occurs between 6 and 24 months of age, although in developing countries cases are common among children younger than 6 months (65). Data from numerous longitudinal studies conducted in both developed and developing countries show that repeated rotavirus infections, mostly involving different serotypes, are common throughout life, particularly during the early years (66–68). In general, both older children and adults develop asymptomatic rotavirus reinfections, mostly as a result of close (e.g., intrafamilial or institutional) contact with an infected infant (15, 69). Finally, rotavirus infections among neonates are more likely to be asymptomatic, possibly because of passively transferred maternal antibodies, the occurrence of apparently attenuated strains within hospital nurseries (70), or the immaturity of the neonatal gut.

According to a recent review by Cook et al. (18) of 34 studies, covering 23 countries, the seasonality of rotavirus infections in temperate regions peaks broadly from autumn to spring. In contrast, seasonal peaks are less distinct in the tropic zones, where rotavirus infections seem to occur year-round.

Data from investigations around the world indicate that rotaviruses account for between 11% and 71% (average, 33%) of diarrheal episodes requiring hospitalization among children younger than 3 years (18), and 40% of nosocomial diarrheal episodes among pediatric populations (71–73).

The proportion of diarrheal cases attributable to rotavirus is generally

in the range of 6% to 24%, according to community-based surveys (74–76). Data from longitudinal community-based studies indicate that the incidence of rotavirus diarrhea may range from 0.15 to 0.8 episodes per child per year (1, 22).

Most of the studies in both inpatient and outpatient settings in Latin America involve children aged less than 5 years. Depending on the setting and study, 11.4% to 60% of children with acute diarrhea were found to have rotavirus. For each of the countries, the rates were: Argentina, 12.9% to 34% (77, 78); Brazil, 13% to 40% (79–81); Chile, 11.4% to 40% (82, 83); Costa Rica, 45.3% to 60% (84, 85); Ecuador, 21.1% (86); Mexico, 14% to 32% (87, 88); and Venezuela, 30% to 50% (75). Community-based studies have yielded average incidence rates of rotavirus infantile diarrhea that range from 0.17 episode/child/year to 0.8 episode/child/year, as follows: Argentina, 0.25 (89); Brazil, 0.3 (68); Chile, 0.8 (90); Costa Rica, 0.8 (85); Guatemala, 0.8 (85); and Venezuela, 0.17 (75).

Data on the epidemiology of rotavirus serotypes in Latin America are still scarce. All four epidemiologically important G types have been identified, and several surveys carried out to date indicate that predominant rotavirus serotypes seem to change over time. In general, a particular type will predominate for 1 or 2 years before the emergence of a new dominant strain, perhaps as a result of immune selection (68, 91–97). The occurrence of rotavirus G type 5 has been claimed to be of emerging epidemiological importance by some authors and might be considered for inclusion in the composition of future vaccines (98, 99). Few studies have been made on the distribution of rotavirus P types in Latin American countries. Recently, an extensive survey carried out in several states of Brazil indicated that the predominant strains are similar to those most commonly found in other parts of the world: P[8]G1, 43%; P[4]G2, 12%; and P[8]G3, 6%. Mixed infections accounted for 21% of the cases, and

such unusual types as P[8]G5 accounted for another 12% of the cases (99, 100). Bearing G1, G3, or G4 specificity, the genotype P[6] has been characterized from studies involving newborn infants in hospital nurseries in Venezuela (42).

Immunity to rotavirus infection

Although several studies have been made on the immune response to rotavirus infections in humans and the other animals, the mechanisms underlying protection against rotavirus disease are not yet fully understood. It is currently accepted that clinical protection may involve local (mucosal) and systemic antibodies, and/or the cell-mediated immune system (34, 101, 102). Although VP6 has been recognized as the most immunogenic rotaviral protein, genetic studies have demonstrated that serum antibodies directed at either VP4 or VP7 are also able to neutralize rotavirus and protect susceptible hosts (34, 103, 104). In addition, a number of studies support the hypothesis that VP4 may be more effective in evoking virus-specific serum neutralizing antibodies during natural infection. On the other hand, antibodies against VP6 in secretions are indicative of the ability of immunoglobulin A (IgA) to neutralize virus, thus reflecting mucosal immunity and resistance to reinfection (105, 106).

Numerous previous studies have suggested that natural infection with rotaviruses confers protection against clinically significant disease during reinfection. Some reports indicate that neonates infected within their first 2 weeks of life are protected against moderate-to-severe disease but not against reinfection (101, 107). Similarly, infants and children are protected against rotavirus disease following both symptomatic and asymptomatic primary infection (59, 108). The occurrence of symptomatic reinfection, on the other hand, suggests that, following natural infection, protection against the disease may be short-lived or incomplete (95, 101, 109–111). In a

recent follow-up study involving Mexican infants, it was shown that each new rotavirus infection increases natural protection and reduces the severity of the diarrhea (112). It remains uncertain whether or not serotype specificity of the immune response is related to clinical immunity during natural infection. Although homotypic responses seem to predominate, numerous studies involving humans and other animal models have shown that heterotypic responses are commonly elicited, even after primary infection (104, 113, 114). On the other hand, the occurrence of sequential rotavirus illnesses involving the same G type, reported by several investigators, supports the view that natural infections produce incomplete protection (110, 115, 116).

Both primary and secondary infections in humans elicit the development of antirotavirus antibodies of the IgG, IgM, and IgA classes in serum, saliva, and intestinal secretions (28, 30, 117). It has been suggested that high levels of serotype-specific serum neutralizing antibodies are closely associated with protection against relatively severe disease (109, 118). According to other authors, however, the immunologic response occurring at the intestinal mucosal surface (mainly in terms of rotavirus-specific secretory IgA) would probably be a more consistent predictor of clinical immunity (102, 119, 120). In addition, the often short-lived nature of protection induced by natural infection is in line with the short-term secretory IgA response (121).

To date, investigations on the potential role of cellular immunity in rotaviral infection have been made mainly in nonhuman models (122, 123). In mice, immune cytotoxic T cells may represent a major component of host defense in the gastrointestinal tract (124). This cytotoxic T lymphocyte activity is linked primarily to CD8 (and possibly CD4) cells and seems to mediate virus clearance rather than confer complete immunity to rotavirus reinfection (102, 125). In addition, mechanisms leading to the release of antiviral toxins (e.g., interferon-gamma and tumor necrosis

factor-alpha) may play a role in the protection against infection (126).

In addition, passive immunity from transplacental transfer of antibodies and breast-feeding may play a role in protection against rotaviral disease in young infants (26, 127, 128). This view is supported by findings from numerous studies, indicating that infants do not usually develop severe rotavirus illnesses during their first 6 months of life. Although the protective role of breast-feeding is still controversial, it has been demonstrated that mothers of uninfected neonates possess higher levels of rotavirus-specific neutralizing antibodies (NA) in colostrum and milk than do mothers of infected neonates (129). Nonimmunological protective factors present in human milk, such as mucinlike glycoproteins, have been claimed by some authors to inhibit rotavirus infection (130). Of interest are recent studies involving Bangladeshi children, which indicate that exclusive breast-feeding protects against rotavirus infection during the first year of life; however, the infection is postponed to the second year of life (131). Another potential mechanism of passive immunity is the transfer of maternal IgG to the intestinal lumen in both humans and other animals, possibly through transcytosis, leading to virus neutralization prior to infection of enterocytes, if antibodies are present in sufficient concentration (102).

Also in the context of passive immunity, some studies have shown that prophylactic protection against infection and clinically significant illness in infants can be afforded by oral administration of either milk or colostrum containing rotavirus-specific antibodies (132, 133).

APPROACHES TO ROTAVIRUS VACCINE DEVELOPMENT

To date, many approaches to the development of rotavirus vaccines have been attempted, not to *prevent* infection or mild disease but rather to *protect against* life-threatening dehydrating diarrhea (22, 23). Early vaccine

trials demonstrated that a low proportion of infants receiving a monovalent vaccine developed a heterotypic antibody response (23). As a result, current strategies are directed toward developing multivalent vaccines that bear epitopes similar to the circulating rotavirus serotypes (23, 134). Several field trials with reassortant multivalent rotavirus vaccines have been completed around the world. Furthermore, because data from several studies—most of them involving nonhuman models—indicate that mucosal immunity rather than circulating antibody plays a major role in reducing the incidence or severity of infection (119, 120, 135), current strategies are primarily directed toward developing an orally administered live attenuated rotavirus vaccine (36). In addition, the recent discovery that rotavirus nonstructural protein NSP4 may act as a viral enterotoxin in nonhuman models offers new and exciting approaches toward the prevention of rotavirus diarrheal illness (37, 136). Using inactivated vaccines to immunize pregnant women, in an attempt to enhance the passive transfer of specific antibodies through the placenta and breast milk, has also been regarded as an alternative approach for protecting against rotavirus diarrhea (27).

Below, we briefly discuss recent major strategies adopted for the development of a rotavirus vaccine, with emphasis on rotavirus vaccines of both human and nonhuman origin and the human × nonhuman reassortant rotavirus vaccines (Table 1). In addition, we highlight the most significant observations resulting from field trials carried out in various parts of the world, focusing on those conducted in developing countries.

Rotavirus vaccines of nonhuman origin

Initial attempts to develop a live attenuated rotavirus vaccine were based on the fact that most nonhuman and human rotavirus strains share major common antigens, particularly VP6.

Therefore, in a manner similar to that adopted by Edward Jenner 200 years ago (the “Jennerian approach”), a related live attenuated agent of nonhuman origin would be expected to act as immunogen when administered to humans (36). The first human candidate vaccine was an attenuated bovine (G type 6) rotavirus strain, the Nebraska calf diarrhea virus (NCDV) (137). Of particular interest were the early findings showing that *in utero* inoculation of NCDV induces cross-protection in calves against challenge by human rotaviruses (138).

To date, three candidate monovalent vaccines prepared from nonhuman rotaviruses have undergone field trials. Two of the vaccines have been derived from a bovine source (RIT 4237 and WC3 strains, serotype 6

viruses), and one vaccine (RRV MMU 18006, serotype 3 virus) was of simian origin (106, 139, 140).

The RIT 4237 was essentially a high primate cell culture passage cold-adapted strain developed from the bovine strain NCDV. The phase I clinical trials with this candidate vaccine first involved adults and later infants as young as 1 month of age; both of them received a high dose (approximately 10⁸ 50% tissue culture infective dose), administered orally. No adverse clinical effects were noted among the recipients, and virus shedding was minimal (141–143). Subsequently, several efficacy trials were carried out in both developed and developing countries. Placebo-controlled efficacy trials among Finnish infants achieved protection rates of 50% to

TABLE 1. Origin and related G- and P-types of rotavirus vaccine strains studied to date

Rotavirus vaccine strains	Related G- and P-types
Nonhuman origin	
Bovine	
RIT 4237	P[1], G6
WC3	P[5], G6
Simian	
RRV MMU 18006	P[3], G3
Animal-human reassortant strains	
Bovine-human reassortants	
WI78-8	P[5], G3
WI79-9	P[5], G1
SC2-9	P[5], G2
D ₇ A	P[5], G2
WI79-4	P[8], G6
WI61-4	P[8], G6
WC3-quadrivalent	P[5], G1,2,3 + P[8], G6
Rhesus-human reassortant strains	
D X RRV	P[3], G1
DS1 X RRV	P[3], G2
RRV-TV	P[3], G1,2,3,4
Human rotavirus strains	
M37	P[6], G1
RV3	P[6], G3
116E	P[11], G9
I321	P[11], G10
89-12	P[8], G1
Nonreplicating rotavirus vaccines	
Viral capsids lacking RNA	
Recombinant proteins expressed in bacterial/viral vectors	
Synthetic peptides as subunit vaccines	
Nucleic acid vaccines	

60% against all rotavirus diarrhea, and over 80% protection from clinically significant diarrhea (144). In later phase III studies made in the African countries of the Gambia (145) and Rwanda (146) and on the White River Indian Reservation in the United States (147) RIT 4237 failed to provide protection against rotavirus disease. Finally, in a trial carried out in Lima, Peru, comparing the protective effect of one, two, or three vaccine doses, RIT 4237 vaccine was effective in protecting against G type 1 rotavirus diarrhea, particularly against severe disease (148). In the Peru study three doses of the vaccine conferred 40% protection against any rotavirus diarrheal episode and 58%–75% against severe rotaviral illnesses. The efficacy rate was 90% against severe diarrheal episodes due to G type 1 rotavirus. In spite of the results in Peru, inconsistent results obtained from field trials of RIT 4237 led to the discontinuation of further development of this vaccine (121).

Another monovalent rotavirus candidate vaccine of bovine source is the WC3. This vaccine was developed by the Wistar Institute, Philadelphia, Pennsylvania, United States, after 12 cell-culture passages of a bovine rotavirus strain isolated from a calf with diarrhea (149). The surface protein composition of the WC3 strain indicates that, like NCDV, it belongs to serotype G6, but it has a P type 5 specificity (150). The vaccine was orally administered and consisted of live virus in high titer (usually $\geq 10^{7.0}$ plaque-forming units (PFU) per dose). No side effects were noted in several clinical trials in which more than 500 infants received approximately 10^7 PFU of the vaccine (147, 149). On the other hand, the fecal shedding of virus was found to be lower than 30% among vaccine recipients (149). This vaccine induced high levels of serum neutralizing antibodies to the homologous virus WC3, often approaching 100%; however, few seroconversions to the most prevalent human serotypes were observed. Infants who had rotavirus serum antibodies prior to vaccination developed a broad hetero-

typic booster response, including an increase in neutralizing antibody levels to all four major human G types (108, 149, 151).

Efficacy trials for WC3 were carried out in both developed and developing countries, resulting in variable degrees of protection. In an initial double-blind placebo-controlled efficacy trial conducted in Philadelphia, one dose of vaccine induced 100% protection against moderate-to-severe diarrhea associated with rotavirus G type 1 infection (139). In contrast, subsequent field trials in the Central African Republic, China, and the United States showed protective efficacies that ranged from 0% to 50% against moderate-to-severe rotavirus diarrhea (108, 121, 152).

Major efforts were now directed toward the evaluation of a vaccine strain originally recovered from a young rhesus monkey with acute diarrhea, MMU 18006 (generally called RRV, for rhesus rotavirus vaccine) (153). This vaccine was developed as an alternative to those of bovine origin because it shares neutralization specificity with the G type 3 human rotavirus (154, 155). In addition, RRV is readily cultured in DBS-FRHL₂ cells, a semicontinuous diploid fetal rhesus lung cell line developed by the United States Food and Drug Administration (156). For clinical trials the vaccine was prepared from virus produced in 16th cell culture passage in the monkey diploid cells, and doses tested were either $10^{4.0}$ or $10^{5.0}$ PFU per infant.

The MMU 18006 vaccine was thoroughly tested in phase I and phase II studies carried out in Finland, Sweden, the United States, and Venezuela. In general, this vaccine was found to be both more immunogenic and reactogenic in young children than the bovine-origin rotavirus vaccine strains (19, 157–159). Mild, transient fever was recorded 2 to 4 days after inoculation in 9% to 40% of infants, but reactogenicity was diminished in the presence of maternal antibody. In addition, RRV was shed in feces of more than 10% of vaccine recipients, and it induced gastroenteric symptoms in a

small proportion of inoculated infants (160–162). It has been shown that RRV elicits secretory intestinal antibody in immunized infants and, as with the use of bovine-origin vaccine strains, the neutralizing antibody response to human rotavirus G serotypes is evident only in infants who were seropositive prior to vaccination (160, 163). Other serological studies with RRV have indicated that adult vaccinees develop both a homotypic neutralizing (VP7 and VP4) antibody response to the immunizing strain and a heterotypic response to other serotypes. Infants also develop homotypic neutralizing antibody response but, unlike the adults, they show markedly less heterotypic immunity (29).

Phase III vaccination studies with RRV were carried out in several settings around the world, yielding variable rates of protection among infants who were naturally challenged by rotavirus G type 1 (163–167). Some of these trials showed that protective efficacy rates against moderate-to-severe rotavirus illness may exceed those for all rotavirus diarrhea (164, 168). Of interest is a vaccine trial conducted in Caracas, Venezuela, (169), where the prevailing rotavirus type was G3. RRV proved to be 64% efficacious against any rotavirus diarrhea, and vaccine efficacy reached 90% against more severe cases. Ukae et al. (170) in Sapporo, Japan, have found that a booster dose may enhance the heterotypic protection induced by RRV.

The wide variability of results from field trials with monotypic vaccines has been attributed to their inability to induce protection against the four epidemiologically important G types in infants who had not been primed by rotavirus infection before vaccination (36). As a result, in a “modified” Jennerian approach “second-generation” polyvalent reassortant candidate vaccines were developed in an attempt to broaden the protective spectrum, mainly against the four predominant human rotavirus serotypes, G1 to G4. Bearing human G- or P-type specificity, these reassortants have been

constructed by using simian (RRV) and bovine (WC3) strains (150, 157, 171, 172).

Animal-human reassortant rotavirus vaccines

Bovine-human reassortant rotavirus vaccines. Several reassortants were constructed with the purpose of combining the safety and immunogenicity of the bovine strain WC3 with the antigenic specificities of predominant human rotavirus serotypes. These strains were generated by incorporating human rotavirus genes (usually 8 or 9) coding for surface proteins of G1, G2, G3, or P1 specificity to a genome background of WC3.

The first reassortant strain to be clinically evaluated was WI78-8, which has a surface protein composition characterized as P[5], G3. WI78-8 contains genes 2 to 5 from WC3, and the remaining genes come from the human G3 strain WI78. This candidate vaccine proved to be safe among infants receiving 10^6 PFU per dose, and two doses induced seroresponse rates of 40% against WC3 and of $\geq 54\%$ against a homologous WI78-8 strain (150).

A further bovine-human reassortant rotavirus strain constructed was WI79-9, which primarily provided protection against the G1 serotype, known to be the predominant type throughout the United States. The WI79-9 genomic composition included the gene segment 9 encoding the VP7 protein derived from the human rotavirus WI79 (a G1 serotype), with remaining genes from the bovine rotavirus strain WC3 (150, 171). This reassortant, at 10^7 PFU/dose, was not associated with any adverse reactions in an efficacy trial among 77 infants aged 2 to 11 months in the United States (150, 173). Of particular interest in this trial was the 100% protective efficacy against rotavirus diarrhea caused by either serotypes G1 or G3, after two doses of the WI79-9 rotavirus strain. In addition, neutralizing antibody seroresponses to WC3 and WI79 were noted in 97% and 22% of vaccinees, respec-

tively, indicating that VP4 is likely to be more immunogenic than VP7. A larger clinical efficacy trial administered three doses of WI79-9 at 10^7 PFU/dose to a total of 325 infants in two cities in the United States. Done in Rochester and Philadelphia, the trial resulted in protective efficacy rates of 64% and 74%, respectively, against all symptomatic rotavirus episodes (174). Taken together, the data from the two cities indicate that the vaccine was associated with a 65% reduction in all relatively severe diarrheal episodes, regardless of the etiology. No adverse reactions were attributable to the vaccine within 7 days following vaccination.

Two WC3-based reassortant strains, SC2-9 and D₇A, were developed with human rotavirus G serotype 2 specificity (150). The former strain was designed to contain the gene encoding the G2 type VP7 from SC2 on a WC3 genome background, while the latter was constructed to give a genome composition involving genes 2, 4, 10, and 11 from WC3 and the remaining genome of SC2 strain. Seroresponse rates among infants given two doses at 10^7 PFU per dose of either reassortant reached about 80% to rotavirus of WC3 or SC2 specificity, or to both. G2-type seroresponses were slightly more frequent among infants vaccinated with SC2-9 reassortant (55%) than among infants given the D₇A strain (32%).

An additional, recent approach with bovine-human reassortant rotavirus vaccines was the construction of strains in which the genes coding for predominant human rotavirus P types were added to a WC3 genome. These reassortants were produced on the assumption that, unlike reassortants based on human rotavirus (HRV) VP7, HRV VP4 might preferentially induce HRV-specific neutralizing antibodies and presumably yield enhanced protection. One of these reassortants, WI79-4, contained gene 4 of WI79 (G1 serotype), which bears genotype 8 serotype 1A specificity. A broad, cross-reactive protective immunity would be expected, since serotype 1A[genotype 8] is shared by most of

the G1, G3, G4, and G9 HRV strains (175). A second reassortant was WI61-4, which contained gene 4 of WI61, characterized as a P1A[8], G9 strain. No adverse reactions were noted among infants given either reassortants and, surprisingly, neutralizing antibody responses to WC3 were again significantly more frequent than for human rotavirus parent strains from which VP4 genes were obtained (150). A further, double-reassortant strain was constructed, WI79 (4+9). It had genes for VP4 and VP7 of human P[8], G1 strain WI79 on a WC3 background. However, no improved immunogenicity of this vaccine was observed among infants after the administration of two doses of 10^7 PFU. In contrast, and again surprisingly, more recent investigations indicate that the mixture of WI79-9 with WI79-4 reassortant strains is a potent immunogen. Two doses of this mixture given to infants induced 97% and 71% neutralizing antibody seroresponses to WC3 and HRV WI79, respectively (150).

In an attempt to achieve homotypic protection against the major wild human rotavirus G types, a quadrivalent WC3-based vaccine was constructed. In one dose it incorporated 10^7 PFU of three VP7 reassortants: WI79-9 (G1), SC2-9 (G2), and WI78-8 (G3). The fourth component was 5.0×10^6 PFU of the human VP4 reassortant WI79-4 (150, 173). A preliminary evaluation of the safety and efficacy of this vaccine has been made in the United States, involving 417 infants from 10 different cities (176). Following a three-dose regimen of the vaccine, no significant side effects were detected, and protection against all rotavirus diarrheal episodes was 67%.

Other human-bovine rotavirus reassortant strains have been assembled using bovine rotavirus UK as the donor strain. The reassortants result from incorporation of the VP7 gene, derived from human rotavirus strains D, DS1, P, or ST3 (G serotypes 1, 2, 3, and 4, respectively), into a UK genome background (172, 173). Recent safety and immunogenicity studies with

these reassortant strains have yielded satisfactory levels of attenuation, safety, infectivity, and immunogenicity. These results justify further testing of a candidate vaccine combining these four reassortants (177). An alternative approach for the UK-based vaccines has been the construction of reassortants containing VP4 protein derived from Wa (a G1, 1A[8] strain), along with VP7 protein derived from DS1, characterized as being G2, 1B[4] (173). This vaccine has the potential to protect against the predominant worldwide human rotavirus G types.

Rhesus-human reassortant rotavirus vaccine. Rhesus-human reassortant rotavirus strains have a single human rotavirus gene specifying the neutralization viral protein VP7, with the remaining 10 genes coming from the parent, rhesus monkey strain. The strains were developed at the National Institute of Allergy and Infectious Diseases, Bethesda, Maryland, United States. This work involved the cocultivation of fastidious human viruses with the tissue culture-adapted RRV strain MMU 18006, and the subsequent selection of single gene substitution rhesus-human reassortants expressing the VP7 from human G serotypes 1, 2, and 4 (172, 178). These strains have been evaluated either individually or as a quadrivalent preparation containing G types 1, 2, and 4 reassortants, along with RRV as the component having homology with the human G serotype 3.

Field trials with the single serotype rhesus-human vaccines in Finland and the United States have shown protection following a single dose of 10^4 PFU (167, 179). The protective efficacy was not necessarily serotype-specific, and it appeared to last more than a year. In addition, protection was greatest in infants with a serum IgA antibody response to the vaccine, and was possibly greater for severe diarrheal episodes than for mild illness. In Finland, where G serotype 1 was prevalent, the rates of protection conferred by the rhesus-human vaccine with specificity for

G serotype 1 (D \times RRV) or 2 (DS1 \times RRV) averaged 66% and 38%, respectively, in the first and second rotavirus epidemic seasons after vaccination (179). For infants showing a serum IgA antibody response, the corresponding figures were 92% and 59%.

In a placebo-controlled field trial conducted in the United States, in the city of Rochester, the D \times RRV G type 1-specific reassortant was found to be mildly reactogenic and immunogenic, inducing serum antibody responses in 71% of the vaccinees (167). Its protective efficacy against rotavirus-associated illness among vaccinees over three rotavirus seasons was 67.3%, and homotypic protection against the predominant G type 1 reached 72.8%. Also in the United States the monovalent G type 1 vaccine (D \times RRV) has been evaluated, together with the tetravalent preparation, RRV-TV. That national multicenter trial involved 1 278 healthy infants aged 5 to 25 weeks. After three doses, which were given at approximately 2, 4, and 6 months of age, the vaccine proved to be safe and 54% efficacious against any rotavirus diarrheal episode (180). Another multicenter efficacy trial in the United States concurrently evaluated the D \times RRV and RRV-TV vaccines. However, no consistent correlates of immunity against rotavirus infection or disease were found, based on either enzyme-linked immunosorbent assay (ELISA) IgA or serotype-specific neutralizing antibody seroconversions (181).

The immunogenicity, safety, and protective efficacy of a single dose of the D \times RRV vaccine and of the G serotype 2 reassortant (DS1 \times RRV) vaccine were tested in a recent field trial in Lima, Peru (160). Neither diarrhea nor other side effects were associated with the administration of either of the vaccines. Approximately 50% of the vaccinees in both vaccine groups developed an IgA ELISA seroresponse, but serotype-specific neutralizing antibodies were induced in fewer than 20% of the participants. In addition, and contrasting with results from trials in both Finland and the

United States, D \times RRV and DS1 \times RRV failed to provide an adequate serotype-specific response in infants vaccinated at 2 months of age.

In an attempt to broaden the protective spectrum of the rotavirus vaccine, a tetravalent formulation was produced. This RRV-TV formulation incorporated human-rhesus reassortants, representing G1, G2, and G4, along with RRV to represent G3 (Figure 1). Phase I studies have indicated that the vaccine is generally safe. However, a greater number of febrile reactions have been recorded in vaccinees after the first dose than have been noted in infants given placebo. Significant IgA ELISA and neutralizing antibody (NA) seroconversion rates (66%–83%) to RRV have contrasted with the low levels of NA seroresponse (from less than 20%, to 43%) to human G serotypes 1 to 4 (23, 134, 157, 169, 182–185).

Several trials have evaluated the protective efficacy of RRV-TV. Three trials conducted in the United States yielded promising results (164, 186, 187). In the first trial (164), three doses of RRV-TV at 4×10^4 PFU/dose evoked 57% protection against any rotavirus disease (mostly by rotavirus G type 1) over a 2-year period. For cases of very severe rotavirus gastroenteritis, protection exceeded 80%. A small excess of febrile reactions was noted after the first dose. NA seroresponses to G types 1–4 were low, again contrasting with the high (nearly 90%) NA seroconversion rate to RRV. Interestingly, no consistent correlation was noted between rotavirus antibody responses after vaccination and protection, as shown by the examination of serum samples from a subset of infants enrolled in the trial (181).

These promising results were confirmed in a second large efficacy trial in the United States, involving 1 278 infants from 24 centers throughout the country (186). Three doses of either a 4×10^5 PFU/dose formulation of RRV-TV or placebo were given to healthy infants at approximately 2, 4, and 6 months of age. With the excep-

FIGURE 1. Schematic representation of genetic reassortment that occurs during the production of tetravalent rhesus-human reassortant rotavirus vaccine (RRV-TV). Adapted from Kapikian et al. (19), with permission

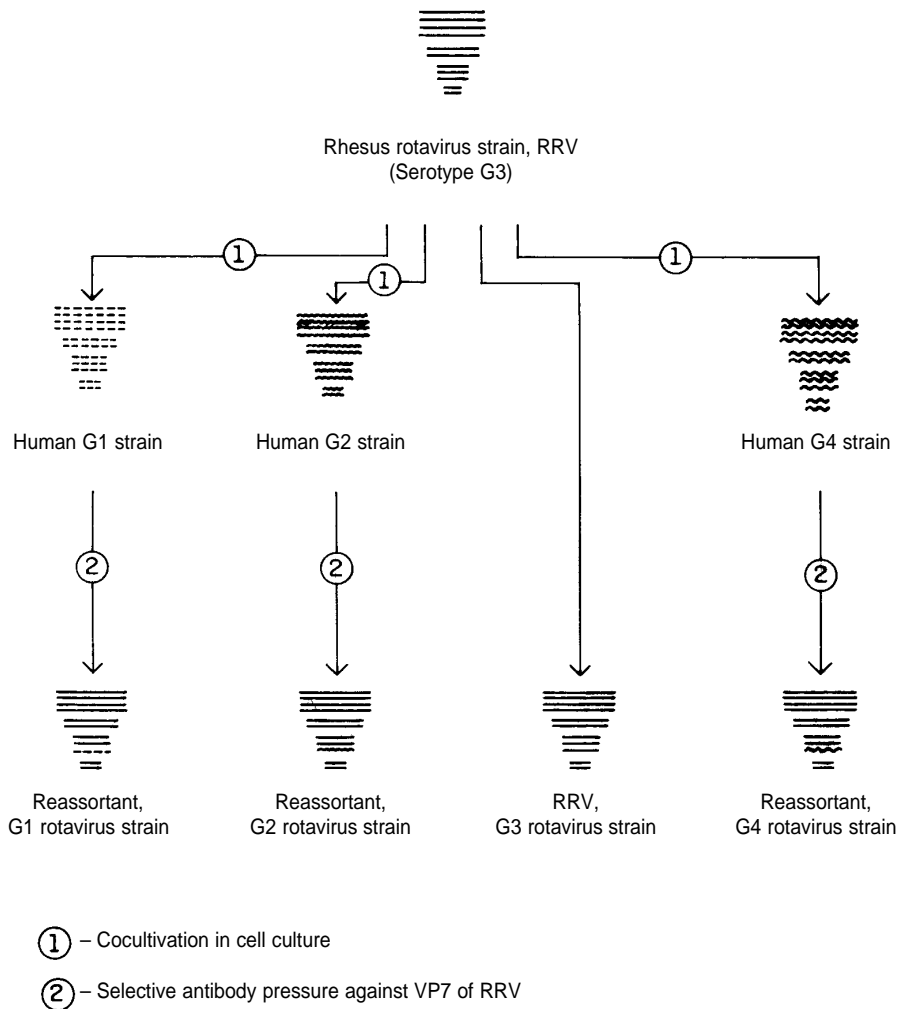

tion of a limited febrile reaction after the first dose, the vaccine was well tolerated. The NA seroconversion rates were also low for G1-4 human serotypes (4% to 31%), whereas seroresponse to RRV among the vaccinees reached 90%. Of particular interest in this study were the protective efficacy rates for RRV-TV: 49% against all rotavirus diarrheal episodes, 80% against the very severe cases of gastroenteritis, and 100% against the dehydrating rotavirus illnesses.

The three-dose regimen schedule for RRV-TV adopted in these two exten-

sive trials in the United States (164, 186) resulted from the demonstration by Pichichero et al. (188) that, although it is safe, a single dose of the quadrivalent vaccine at 10^4 and 10^5 PFU/dose is not adequately immunogenic.

The third trial in the United States evaluated the efficacy and safety of the high-dose (4×10^5 PFU/dose) RRV-TV with Native American infants aged 6 to 24 weeks old (187). The vaccine was well tolerated and yielded efficacy rates of 50% and 69% against all rotavirus diseases and severe rotavirus diseases, respectively.

The protective efficacy of RRV-TV has been thoroughly evaluated in other countries, including Brazil, Finland, Peru, and Venezuela. In a recent placebo-controlled efficacy trial, 2 398 Finnish infants received three doses of either the RRV-TV vaccine (4×10^5 PFU/dose) or placebo, between 2 and 7 months of age (189, 190). These authors detected a febrile reaction rate of about 30% among the infants given the vaccine. RRV-TV was found to reduce severe rotavirus disease by 90% and all severe gastroenteritis in young children by 60%.

The first rotavirus vaccine field trial conducted in a developing country, to assess the protective efficacy, immunogenicity, and safety of RRV-TV, was carried out in Lima, Peru, by Lanata et al. (166). At the ages of 2, 3, and 4 months, 700 infants were given a dose (4×10^4 PFU) of RRV-TV, an initial dose of vaccine followed by placebo at 3 and 4 months, or a dose of placebo. Neither one nor three doses of RRV-TV was significantly efficacious against all episodes of rotavirus diarrhea, when compared with the placebo. However, a three-dose regimen of RRV-TV provided moderate but significant protection (35%–66%) against more severe episodes of rotavirus diarrhea, mainly those cases associated with serotype G1. The incidence of diarrhea, vomiting, and fever during 6 consecutive days after the first, second, and third doses did not differ significantly between the vaccinees and the infants given a placebo. IgA seroresponse after three doses, as determined by ELISA, was 75% in the vaccine group and 24% among the placebo recipients ($P < 0.001$). On the other hand, neutralizing antibody response to at least one G type, as measured by plaque reduction neutralization (PRN) assay, was detected among 64% and 12% of the three-dose study group and placebo recipients, respectively ($P < 0.001$).

In Belém, a city in the northern Brazilian state of Pará, RRV-TV (also 4×10^4 PFU/dose) was evaluated for safety, immunogenicity, and efficacy in a 2-year prospective randomized

TABLE 2. Protective efficacy of rotavirus vaccines in field trials in Latin America

Vaccine/ Study site	No. of doses × vaccine titers ^a	Ages (mo) at vaccination	Efficacy (%)	
			All rotavirus diarrhea	Severe rotavirus diarrhea
RIT 4237				
Lima, Peru	3 × 10 ⁸	2–18	40	75
RRV				
Caracas, Venezuela	1 × 10 ⁴	1–10	68	100
Lima, Peru	1 × 10 ⁴	3–12	29	29
RRV-TV				
Lima, Peru	1 × (4 × 10 ⁴)	2	18	0–59
Lima, Peru	3 × (4 × 10 ⁴)	2–4	24	0–47
Belém, Brazil	3 × (4 × 10 ⁴)	1–5	35	56
Caracas, Venezuela	3 × (4 × 10 ⁵)	2–4	48	88

^a The titer given is plaque-forming units per dose.

double-blind placebo-controlled trial involving 540 infants (191) (Table 2). The infants received three doses either of vaccine or of placebo at 1, 3, and 5 months of age. The overall vaccine efficacy against any rotavirus diarrhea was 35% for the 2 years of surveillance. During the first year there was a 57% protection against rotavirus diarrheal episodes, most of them associated with G type 1. In contrast, the vaccine efficacy fell to 12% in the second year of follow-up. There was an interesting tendency among RRV-TV recipients towards enhanced protection against illness associated with an average of six or more stools per day. Low-grade fever occurred on days 3 to 5 after the first dose in 2%–3% of the vaccinees. With that exception, no statistically significant differences in the incidence rates of other adverse events, such as diarrhea and vomiting during the week following vaccination, were noted between the two study groups. After three doses, about 60% of infants vaccinated with the RRV-TV and 33% of those who received placebo had IgA seroconversion. On the other hand, NA seroconversions rates to individual G1 to G4

serotypes did not exceed 20% when measured by fluorescent focus reduction assay, but were greater than 40% when assayed by PRN.

A recent reanalysis of the Peruvian and Brazilian efficacy data indicates that lower-titer RRV-TV was potentially efficacious against severe rotavirus disease in Peru with one dose of vaccine, and against both severe and very severe rotavirus diarrhea with the three doses given in Brazil (192). In Brazil the vaccine was 75% protective against very severe diarrheal episodes (192).

Of particular importance for developing countries were the results from a large catchment efficacy trial of the RRV-TV in Caracas, Venezuela (193) (Table 2). The main objective of the trial was to assess the protective efficacy of high-dose RRV-TV (4 × 10⁵ PFU/dose) against moderate or severe dehydrating diarrheal episodes. In the study three doses of vaccine or placebo were administered to 2 207 infants at 4-week intervals, starting at the second month of age. The children were then passively followed up to the age of 24 months in order to detect rotavirus diarrheal episodes. Although

generally well tolerated, the RRV-TV induced febrile reactions in 15% of vaccinated infants within 6 days after vaccination, as compared with 7% of those in the control group (*P* < 0.001). The vaccine was highly effective against severe rotavirus gastroenteritis. It provided protection rates of 88% against severe diarrhea and of 75% against dehydration and also produced a 70% reduction in hospital admissions.

The issue of intussusception. On 31 August 1998 the United States Food and Drug Administration (FDA) licensed the RRV-TV RotaShield[®] vaccine (Wyeth Laboratories, Inc., Marietta, Pennsylvania, United States) for vaccination of infants in the United States. In addition, recommendations to use the vaccine among healthy infants, in three doses, at 2, 4, and 6 months of age, were made by three other organizations in the United States: the Advisory Committee on Immunization Practices (ACIP), the American Academy of Pediatrics, and the American Academy of Family Physicians (194). During the following 11 months, an estimated 1.5 million vaccine doses were administered to about 900 000 children in the United States.

In July 1999, however, the United States Centers for Disease Control and Prevention (CDC) suspended use of the RotaShield[®] vaccine, following the report of 15 cases of intussusception among vaccine recipients (195). Intussusception is a condition characterized by the telescoping of one segment of intestine into an adjoining segment, resulting in bowel obstruction. It primarily occurs among infants. The data on which the CDC made its July 1999 decision had been gathered from the Vaccine Adverse Event Reporting System (VAERS), a passive surveillance system operated by the FDA and the CDC. Given the "insensitive" character of VAERS, a concern was raised that the true number of intussusception cases might have been underestimated.

By October 1999 a total of 114 possible intussusception cases had been reported to VAERS, and 99 of them were confirmed as intussusception. Of these 99, 60 of them occurred within 7 days of the first, second, or third vaccination: 49 of the cases after the first vaccine dose, 10 after the second dose, and 1 after the third dose. Surgery was required for 32 patients, including bowel resection in 7 of the infants. One fatal case occurred, with a 5-month-old child.

Other data came from a retrospective multistate case-control study conducted by the CDC and from a cohort study conducted in several large health maintenance organizations in the United States. Together, these studies yielded an initial estimated vaccine-attributable risk of 1 case of intussusception in 4 300 vaccinated infants (196). This estimate has subsequently been revised to approximately 1 case of intussusception for every 10 000 vaccinees (United States, Centers for Disease Control and Prevention, unpublished data).

On 22 October 1999 the ACIP concluded that among vaccinees there is a significantly increased risk of intussusception within 1 week of a dose, and therefore withdrew its recommendation that RRV-TV be administered at 2, 4, and 6 months of age (197). However, the ACIP cautioned that such a decision "may not be applicable to other settings, where the burden of diseases is substantially higher and the risks and benefits of rotavirus immunization could be different." The withdrawal of the only licensed rotavirus vaccine underlined the need to reassess priority activities, particularly future rotavirus vaccine research in developing countries (197). This issue will be discussed further later in this article.

It bears pointing out that intussusception did not emerge as an important adverse reaction during the prelicensure trials. Prior to licensure, among 10 054 vaccinees, 5 cases (0.05%) occurred. In comparison, among the 4 633 placebo recipients there was only 1 case (0.022%). That

difference in intussusception rates was not statistically significant (198, 199). On the vaccine's package insert, the manufacturer had listed this type of bowel obstruction as a potential adverse reaction, and intussusception was also discussed in the ACIP recommendations for use of the vaccine. Other forms of prelicensure evidence were lacking to indicate that intussusception was associated with vaccination. In the prelicensure trials there had been no clustering in time of the intussusception cases among the vaccinees. Further, it was found that the age distribution of the intussusception cases among the vaccinees was similar to that for a large comparison population (198). Finally, there was no evidence associating wild-type rotavirus with intussusception (198, 200–202).

Human rotavirus strains

The first non-Jennerian approach to vaccination against rotavirus was the use of human strains isolated in nurseries for newborns. This strategy was based on evidence from studies in Australia, Sweden, the United Kingdom, and Venezuela indicating that the human rotavirus strains that usually infect neonates seem to be naturally attenuated (23, 36, 140, 183) and confer protection against subsequent severe rotavirus illness for up to 3 years (101, 107). It is interesting that both hybridization and sequence analyses indicate these strains share a unique VP4-encoding gene that differs from the same regions of the G1, G2, G3, and G4 strains associated with severe illness (36).

The first human-origin rotavirus vaccine tested was M37. It is a cell culture-adapted strain (passage 29), characterized as being P[6]G1, that was originally isolated from a neonate in Venezuela who was asymptotically shedding rotavirus. Phase I trials using doses of 10^4 and 10^5 PFU showed that M37 was safe and moderately immunogenic (183, 185, 203, 204). The vaccine was found to be immunogenic in 70% of infants given two

doses of 10^5 PFU, and the neutralizing antibody seroresponses were specific predominantly to the vaccine strain rather than to G1 human strains (192). Only one efficacy study has been done with the M37 strain. Using the vaccine with infants 2–6 months old in Finland, no protection against rotavirus gastroenteritis caused by G1 viruses was found (204).

Another neonatal strain that has been developed as a vaccine strain is RV3, characterized as P[6]G3 (35) and isolated from a 4-day-old infant born in a maternity hospital in Melbourne, Australia (205). Neonates who became naturally infected with this virus developed neutralizing antibodies to G1, G3, and G4 that still persisted by the age of 3 months. The infants were protected against subsequent severe disease caused by rotaviruses of G2 type during their first 3 years of life (23). Data from a recently completed trial indicate that if an immune response is triggered by the vaccine, the child is protected; on the other hand, if there is no evidence of immune response, protection is poor (23, 196).

The 116E (P[11]G9) and the I321 (P[11]G10) strains, isolated from newborns in India, have also been described as potential candidate vaccines, and they are currently being tested among volunteers (107). The former virus is a single gene reassortant between a human parent strain and the VP4 gene of bovine origin, whereas the latter is a bovine-human reassortant strain bearing multiple genes from bovine origin.

Strain 89–12, an attenuated P[8]G1 rotavirus human strain originally isolated from an infant in Cincinnati, Ohio, United States, has recently been tested for safety, immunogenicity, and efficacy (206). Low-grade fever was the only side effect detected, over 90% of the vaccinees seroresponded to the vaccine, and protective efficacy against rotavirus disease was about 90%.

Additional approaches towards the development of human rotavirus vaccines have included adaptation of a G1 human rotavirus type to grow at 26 °C (207), as well as construction of reas-

sortant strains. Recently developed cold-adapted reassortant strains possess VP7 serotypes 1 and 2 specificities. Reassortant viruses are also available that contain VP7 serotype 2 or 3 gene derived from strains DS-1 or P, respectively, and remaining genes from human Wa strain, including the gene that codes for VP4 serotype 1A (154, 173).

Nonreplicating rotavirus vaccines

Although the multivalent, human-animal reassortant vaccines were the first to be licensed for widespread clinical application, several other potential approaches to rotavirus vaccination are currently being pursued. Most of these "next-generation" vaccines include nonreplicating rotavirus vaccines, the development of which has been based on advances in molecular biology. Compared with the live attenuated virus strains, these potential vaccines would have several theoretical advantages. These include safety, particularly in the immunocompromised host; potentially lower manufacturing costs; enhanced stability during transport; removal of possible reversion to virulence of the attenuated strain; and reduction or even elimination of interference by other vaccines or enteric organisms (23). Most of these candidate vaccines were developed for parenteral administration, although there is some evidence that nonreplicating rotaviruses given orally can stimulate the immune system (208). Various approaches to these inactivated rotavirus vaccines are briefly described below.

Viral capsids lacking RNA. The use of differential centrifugation techniques permits the purification of the empty capsids that are commonly present in cell cultures infected with rotavirus. These viral particles lacking RNA have been used to immunize adult female mice subcutaneously prior to parturition, leading to protection of their litters from challenge

(209). It has also been demonstrated that parenteral vaccination of cows with these empty capsids induces a boost in preexisting neutralizing antibody titers (92). This approach is not currently being considered for human use because the available preparations may still contain fully infectious rotavirus particles (23).

Recombinant proteins expressed in bacterial and viral vectors.

Current attempts to express recombinant proteins in a suitable vector have focused mainly on VP7 and VP4 because of their importance in inducing neutralizing antibodies (39). Either full-length or partial-length genes coding for VP7 from human, bovine, and simian origin have been expressed in a variety of bacterial and viral expression systems, including *E. coli*, vaccinia virus, baculovirus, *Salmonella typhi* 21a, and *S. typhimurium* (173, 210, 211). Proteins synthesized in bacterial systems, especially VP7, have been found to be poorly immunogenic when inoculated into experimental animals. This could be explained by the fact that neutralizing epitopes are known to be dependent on conformation, and expressed protein may not reproduce conformational requirements for antigenicity of native outer capsid VP7 (26, 212). Interestingly, cell surface-expressed VP7 of SA11 strain, using recombinant vaccinia virus, proved to be highly immunogenic for mice. This suggests that these new techniques of antigen presentation may improve subunit vaccines (213, 214).

A promising, recent approach has been the cloning of rotavirus genes encoding structural proteins in baculovirus. These recombinant virus systems successfully express proteins that possess native conformation, if compared immunologically and biochemically with native viral proteins (215–217). The coexpression of different combinations of structural proteins and their subsequent self-assembly results in the formation of viruslike particles that are effective immunogens when administered parenterally

to mice and rabbits (215, 216). Adenoviruses have also been used as potential expression vectors, given that the current candidate adenovirus vaccines, for respiratory infections, are administered orally in enteric coated capsules (218). Attempts to produce attenuated adenoviruses that might express relevant, sufficiently immunogenic antigens are under way (219, 220).

Synthetic peptides as subunit vaccines.

This approach is based mainly on the ability of specific synthetic VP7 and VP4 epitopes to induce neutralizing antibodies (26, 221). VP7 peptides that cover most of the amino acid sequence (amino acids 44 to 295) have been synthesized, but no significant neutralizing antibody response has been achieved following their inoculation into experimental animals (23, 26). A few experiments have been carried out with synthetic peptides matching the amino acid sequences of VP4. It has been shown that a synthetic peptide, corresponding to sequence 296–313 of human rotavirus, binds to a neutralizing monoclonal antibody to VP4 (25). On the other hand, VP4 peptide 220–223 was found to prime for a neutralizing antibody response after the inoculation of mice either with intact SA11 or with human ST3 rotavirus strain (222).

Experiments using BALB/c mice have shown a significant increase in immunogenicity by using synthetic peptides corresponding to different well-characterized determinant regions of protein VP6 of a bovine rotavirus linked to an influenza virus hemagglutinin (223).

Although they are still promising as next-generation vaccines, there is little evidence to date that either expressed viral proteins or synthetic peptides will elicit an effective primary local intestinal immune response. However, from experimental studies it appears that peptides may be useful for priming an immune response, either prior to immunization with a live attenuated virus vaccine or as a booster in

antibody levels after the administration of a live vaccine (23, 212).

Nucleic acid vaccines. A new approach to subunit vaccines is based on the direct inoculation of plasmid DNAs that code for specific viral proteins (224). An advantage of this technique is that immunizing proteins expressed by host cells are presented to the immune system in their native forms, thus fully mimicking the natural infection (224, 225). Experimental studies using adult BALB/c mice have shown that plasmid DNAs encoding for murine rotavirus proteins VP4, VP6, or VP7 elicit both serum antibodies and cytotoxic T lymphocyte response. Sufficient to protect mice against challenge with 100 ID₅₀ homotypic virus, these immune responses indicate the potential of DNA vaccination as a new approach towards the control of rotavirus infection (224).

ROTAVIRUS VACCINE ISSUES IN LATIN AMERICA

The available results from rotavirus vaccine trials around the world clearly indicate that efficacy rates are generally higher in developed countries than they are in less developed countries. The history of vaccine trials in Latin America, particularly Brazil and Peru, is similar to that of trials in such other developing countries as the Central African Republic, China, the Gambia, Myanmar, and Rwanda. With the exception of studies in Venezuela, none of the live oral rotavirus vaccines has performed satisfactorily in the developing world; the experiences in Latin America are shown in Table 2.

A number of reasons may explain these comparatively low efficacy rates in developing countries, many of them related to the epidemiology of rotavirus disease in those areas (226). First, it has been suggested that primary vaccine failures may result from the presence of maternal antibody at the time of vaccination and/or interference by oral poliovirus vaccine and

other intestinal viruses. In addition, the failure to boost with subsequent doses can make short-interval vaccination useless. Secondary vaccine failures, on the other hand, may be the consequence of a waning immunity in the presence of a natural challenge with a large infectious dose, or of unusual rotavirus types that are not covered by the vaccine (226).

Further studies are needed to determine specific reasons for vaccine failure. Furthermore, future immunization strategies should be compatible with the Expanded Program on Immunization (EPI) for each country and perhaps preceded by an evaluation of cost-effectiveness. The discussion in the following section will cover current knowledge of rotavirus vaccine-related issues in Latin America, recommendations for further rotavirus vaccine research, and possible future immunization strategies. The recent withdrawal of the only licensed rotavirus vaccine from the market and the resulting need to reassess priority activities will receive particular consideration.

Possible suppressive effect of maternal antibodies

One possible explanation for the reduced efficacy of the rotavirus vaccine in many trials conducted in developing countries is the suppressive effect of maternal antibodies transferred in breast milk or transplacentally. In most tropical regions adults frequently experience rotavirus reinfections, which are usually asymptomatic. It is to be expected, therefore, that high levels of antibodies are transferred from mother to child either as transplacentally acquired immunoglobulin or as breast milk immunoglobulin (173). In this respect, possible improvement in vaccination performance in developing countries may result from dosing with rotavirus vaccine at an age when the maternally acquired antibodies have declined (226). However, this is problematic because of the relatively early age of rotavirus infection in de-

veloping countries compared to developed countries.

Since breast milk contains specific IgA to rotavirus and nonspecific inhibitors of rotavirus replication, there has been concern that breast-feeding might adversely affect the immunogenicity of oral vaccines (227, 228). That issue has been evaluated in at least 13 clinical trials around the world (228). To date, most of the trials with the bovine vaccine strains, the rhesus rotavirus parent strain, and the rhesus-human reassortant monovalent serotype 1 and tetravalent rotavirus vaccines suggest that one dose of vaccine yields fewer seroresponses among breast-fed infants (227–229). However, any differences in seroresponses between those breast-fed and those not breast-fed are overcome following the administration of three doses of RRV-TV (185). However, it also appears that breast-feeding does not compromise the efficacy of rhesus rotavirus reassortant vaccines, particularly if three doses are administered (180, 230).

In developing countries, very few studies have focused on breast-feeding as a factor that may interfere with either vaccine take or protective efficacy. In Lima, Peru, Lanata et al. (148) found no significant differences when comparing seroconversion rates among breast-fed and nonbreast-fed infants who received three doses of RIT 4237. Likewise, among breast-fed and nonbreast-fed Turkish infants the rates of IgA seroconversions did not differ following a single dose of RRV-TV (231).

Early occurrence of natural rotavirus infections

Besides the potential for interference from high levels of rotavirus antibody that are passively transferred from mother to child, the high rates of natural infection in early life may account for the poor immunogenicity of rotavirus vaccine in developing countries. It is also likely that natural early infections may confer some protection from rotavirus disease among both vaccine

and placebo recipients. This may explain, for instance, why the RIT 4237 vaccine in Peru, which was given between 2 and 18 months of age, yielded higher efficacy in the youngest children, that is, the ones with lower rates of natural infection prior to vaccination (148). The occurrence of infections with rotavirus early in life in developing countries makes it imperative that vaccine programs ensure early, timely vaccination of children in these areas, and that those who design vaccine trials take into consideration the local epidemiology of rotavirus.

Possible interference with rotavirus vaccine take by oral poliovirus vaccine and/or other enteric agents

Another cause of primary vaccine failure in developing countries may be interference by oral poliovirus vaccine (OPV) and other enteric viruses (226). Whether or not OPV can be concurrently administered with rotavirus vaccines has been considered in studies around the world. While simultaneous administration of OPV may interfere with the rotavirus antibody response (228), this interference can be overcome by administering three doses of rotavirus vaccine. For instance, in Yugoslavia rates of rotavirus antibody seroconversions among children given both OPV and RIT 4237 were significantly lower than those among infants receiving rotavirus vaccine alone (232). Similarly, studies in Italy with the RIT 4237 vaccine also showed lower seroresponses among vaccinees who had also received OPV (233). Even so, this interference was noted only following the first dose of rotavirus vaccine. No differences were noted following the second dose. Finally, in the Gambia, no significant differences were noted in antibody response to RIT 4237 vaccine among children concurrently vaccinated with OPV (145).

Several rotavirus vaccine immunogenicity studies have involved simultaneous vaccination with OPV, including at least two studies with RRV and

three with RRV-TV. Ho et al. (234) could find no evidence of significant interference in infants in the United States given OPV and RRV simultaneously, and a study with RRV and OPV in Pakistan gave inconclusive results because of the small numbers of subjects (235). Studies in the United States showed no statistically significant differences in antibody responses to rotavirus vaccines among infants receiving OPV and RRV-TV concurrently, as compared with those given OPV alone (183, 236, 237). The potential for interference between RRV-TV in its 10^4 PFU/dose formulation and OPV has been investigated in Bangkok by Migasena et al. (238). Like other researchers, they found that while OPV is likely to interfere with the take of RRV-TV, this can be overcome either by giving three doses or using a higher-titer rotavirus vaccine.

To date, only one investigation has been made comparing the efficacy of rotavirus vaccine given with and without concurrent OPV (236). These authors enrolled 1 278 infants aged 5 to 25 weeks, at 24 sites located throughout the United States. The results showed no major differences in the efficacy rates of RRV-TV (4×10^5 PFU/dose) between children given OPV and RRV-TV simultaneously and those who received RRV-TV alone.

The overall lack of significant interaction of OPV and rotavirus vaccine is encouraging, but this conclusion is based mainly on studies in the United States. Therefore, caution should be exercised in extrapolating these results to developing countries, including those in Latin America, where the potency of OPV varies, OPV vaccination schedule may differ from the schedule in the United States, and a high rate of poliovirus vaccine failure occurs (239). Since immune correlates of protection remain unidentified, it is currently recommended that future trials, particularly in developing countries, address the potential interference by OPV on the efficacy of rotavirus vaccine rather than on its immunogenicity (226, 239).

Wild enteric viruses and possibly other enteropathogens also have the

potential to cause interference and result in primary rotavirus vaccine failure in developing countries. Several studies in these nations show that rates of mixed infections with rotaviruses and other enteric agents are high, often exceeding 25% of all cases of rotavirus-related diarrheal episodes (19). Some vaccine trials in Latin America have monitored the occurrence of diarrheal pathogens other than rotaviruses, with results varying in accordance with the vaccine used. With RIT 4237 in Peru the efficacy rate among children with mixed infections was lower than that found in children with "pure," rotavirus-only infection (145). Similarly, in subsequent studies with RRV and RRV-TV in Peru where mixed infections were common, a trend was observed for higher vaccine efficacy rates against diarrheal episodes in which rotavirus was the only pathogen isolated (160, 166). However, in trials conducted in Brazil (191) and Venezuela (75, 193), where the rate of mixed infection was 50% and 30%, respectively, efficacy rates did not differ between infants with mixed infections and those with rotavirus-only infections.

Efficacy rates and natural challenge by serotypes not covered by the vaccines

It has been shown that live oral rotavirus vaccines of animal origin were both safe and efficacious (> 80%) against severe rotavirus diarrhea in some populations, but gave no protection in others (38). One reason for this variability, particularly in developing countries, may be differences in the rotavirus serotypes making the challenge. Thus, during the early trials with rhesus rotavirus vaccine in Caracas, Venezuela, where G3 was the most common serotype, up to 86% efficacy was obtained (169). In Lima, Peru, however, where serotype G1 was predominant, RRV induced only a low level of heterotypic protection, mainly against serotype G1 (160). High efficacy rates during some RRV

trials in developed countries where G1 was also most prevalent may have been a result of prior priming of participants with a VP7 serotype 1 strain. When boosted by RRV, these infants developed a broadened heterotypic immunity, whereas only a homotypic response was induced among the naive vaccinees (167, 173). Although available quadrivalent vaccines may provide serotype-specific immunity against each of the four major rotavirus serotypes (G1 to G4), monitoring of strain variation is needed, even before introduction of vaccines. In Brazil and India, for example, recent studies have shown that additional serotypes not covered by polyvalent vaccines may be of epidemiological importance (43, 99, 239).

If quadrivalent vaccines are found to give an unsatisfactory level of protection, one approach to pursue, particularly in developing countries, is the generation of a pentavalent vaccine incorporating an additional strain with human rotavirus VP4 specificity (36). An enhanced immunogenicity of such a vaccine would be expected, since the VP4 is known to induce broadly cross-reactive neutralizing antibodies (41).

A recently developed candidate vaccine of human origin, a P[8], G1 strain, was found to be 90% efficacious against rotavirus gastroenteritis of any severity in a small-scale trial conducted in the United States (206). However, larger efficacy trials are needed, especially in developing countries, to determine whether a significant level of protection would also be achieved where serotypes other than that of the vaccine, even uncommon strains, are prevalent.

Appropriate age for vaccination

In general, rotavirus infections occurring within the first 3 months of life are either asymptomatic or lead to a relatively mild illness. However, some studies carried out in developing countries have shown that the burden of rotavirus disease in this age group may be significant. In a cohort study

conducted in northern India, for example, the incidence of rotavirus diarrhea among infants aged 3–5 months was similar to that for infants 6–11 months old, 0.61 and 0.62 events/child/year, respectively (107). This suggests that in developing countries that vaccination early in life, prior to the current routine immunization schedule for OPV and for diphtheria-pertussis-tetanus (DPT) vaccine, may be beneficial. For developed countries it has been recommended that rotavirus vaccines be given to children along with the routine schedule (226). However, several factors remain to be examined regarding the optimal age for immunization in developing countries. Accumulated evidence from studies in these nations, especially India, suggests that the first vaccine dose should possibly be given earlier than the OPV/DPT schedule (107). The introduction of an alternative schedule for rotavirus vaccination would mean increased costs and logistical difficulties, but the administration to neonates of a first dose together with BCG vaccine may be worth considering. Subsequent doses might be administered with both the OPV and DPT vaccination schedule. However, further immunogenicity studies are needed in Latin America to determine the potential for interference of both high-level maternal antibodies and breast-feeding.

Required number of doses

In light of studies carried out thus far in Latin America, it seems that the number of vaccine doses required to achieve good protection is still controversial and requires further evaluation. In a trial conducted in Lima, Peru, with RIT 4237, for example, the results suggested that the protection against serotype 1 rotavirus diarrhea provided by one dose is similar to that achieved with three doses (148). On the other hand, these same authors have shown that more than one dose of this vaccine may be required to give an adequate protection against serotype 2. Further studies in the same

area showed that one dose of 10^4 PFU of RRV vaccine, of $D \times RRV$ vaccine or of $DS1 \times RRV$ vaccine, is not sufficient to induce a high level of serotype-specific protection among infants immunized at 2 months of age (160). A recent phase III study with RRV-TV (10^4 PFU/dose), also carried out in Lima, compared the protective efficacies of one and three doses of this vaccine (166). Both dose regimens failed to induce a significant level of protection against rotavirus diarrhea. In addition, it is evident from studies in Belém, Brazil, that the protection conferred by three doses of RRV-TV (4×10^4 PFU/dose) was substantially less in the second year of follow-up (12%) than it had been in the first year (57%). These results suggest that the duration of vaccine-induced protection could perhaps be improved by providing a fourth, booster dose early in the second year of life (191).

Inclusion of vaccine in the Expanded Program on Immunization

In Latin America the routine Expanded Program on Immunization activities include four visits to the official public health units in the first 9 months of life, and these should be the opportunities for administering rotavirus vaccine. A possible later (e.g., fourth) dose may therefore represent a logistical problem for completing the schedule. Future introduction of rotavirus vaccine in the developing world will possibly include its combination with forthcoming vaccines against such other enteropathogens as *Vibrio cholerae*, enterotoxigenic *E. coli*, and *Shigella* species (240).

Maternal immunization against rotavirus has been regarded as an additional strategy to enhance protection against illness among infants. This is achieved either through an increase in the concentration of rotavirus-specific IgA in breast milk or through the passive prenatal transfer of IgG (227). It is becoming evident, however, that immunizing mothers against rotavirus is unlikely to be a significant public

health activity in developing countries. Instead, it is currently accepted that neonatal vaccination would more effectively prevent early rotavirus illness and might also have a priming effect for subsequent immunizations.

Vaccine introduction in developing countries

The need for a rotavirus vaccine in both developed and developing countries should be based primarily on data from surveillance studies assessing the burden of disease, together with the epidemiologic features of rotavirus diarrhea in each setting. A first step toward this goal, particularly in developing countries, could be the inclusion of hospital-based sentinel surveillance systems to gather prevalence data on severe diarrhea. In addition, routine characterization of circulating rotavirus strains—mainly G and P types—would be useful for determining predominant strains prior to a vaccination program, documenting significant changes in the rates of prevalent types induced by the vaccine, and potentially aiding in explaining any poor program effectiveness that occurs. Certain circulating rotavirus strains that are potentially more difficult to control, such as human rotavirus genotype P[8],G5 in Brazil, could be identified. Plans have been made for the standardization of methodology in strain characterization, to improve comparability of strain prevalence data. According to recent recommendations (196, 226), such hospital-based surveillance is needed to establish baseline disease estimates to monitor the effect of vaccine introduction; detect and explain potential vaccine failures; develop cost-effectiveness models; detect strains potentially not covered by vaccination; and convince policymakers of the importance of rotavirus vaccination campaigns.

When RRV-TV vaccine was approaching licensure for use in the United States, a number of formal recommendations had been made concerning needed further studies with

this vaccine in developing countries (226). For example, it was agreed that large-scale immunization with RRV-TV in developing countries should be preceded by additional studies to evaluate issues concerning both immunogenicity and vaccine effectiveness. Available data indicated that, in general, rotavirus vaccines are less immunogenic in developing than in developed countries, and the reasons for this remain to be determined. In Latin America, studies dealing with dose and schedule of RRV-TV at 4×10^5 PFU were available only from Venezuela, where this vaccine was shown to be immunogenic and effective against severe disease (226). However, participants in field trials with lower-dose RRV-TV, conducted in Peru and Brazil, tended to develop lower immune responses than did the Venezuelan infants (166, 191). Additional phase I and II trials were therefore recommended in order to compare these immune responses with those of studies in which the vaccine proved to be highly immunogenic. Also urgently needed were immunogenicity studies with RRV-TV in Africa and Asia, where no field trials had so far been performed. Subsequent phase III trials were also planned in developing regions so as to expedite future vaccine introduction. These planned vaccine trials were especially intended to produce information on determinants of immune responses, potential effect of interference by concurrent administration of OPV and/or breast milk, optimal age and schedule of vaccination, the utility of a newborn dose administered with BCG, and the effect on vaccine response of such public health programs as zinc or vitamin A supplementation (226).

Also regarded as essential for implementing rotavirus vaccine programs in developing countries is the demonstration of vaccine efficacy and effectiveness. While efficacy reflects the performance of a vaccine under idealized trial conditions, vaccine effectiveness trials provide an indication of performance under the natural situations faced by a public health program

(232). In this respect, the conduct of effectiveness trials rather than efficacy trials was recommended to expedite the introduction of new vaccines into developing countries (241).

Most of the recommendations summarized above were made during a World Health Organization (WHO) conference held in Geneva, Switzerland, in January 1997 that was entitled the Consensus Workshop: Rotavirus Vaccines for the Immunization of Children in Developing Countries (226), at a time when RRV-TV was approaching licensure in the United States. As there was only one trial showing that rotavirus vaccine is effective in a developing country, WHO recommended that one or two large “demonstration projects” be conducted in Latin American countries where the vaccine was likely to be efficacious. Both Carabobo, Venezuela, and Mexico City, Mexico, were identified as sites where such trials could be performed, and additional studies were planned for very poor areas in Africa and Asia. These latter settings would certainly represent a major challenge to the rotavirus vaccine (226). Such prelicensure trials could serve as a basis for cost-effectiveness evaluation in developing countries, and they would also provide data to support future official decisions concerning the funding of rotavirus vaccination.

Available data estimating the economic impact of immunization against rotavirus gastroenteritis came mainly from analyses involving infant populations in the United States (242–244). One study conducted in the United States demonstrated that an immunization program in which three doses of RRV-TV were included in the routine program of childhood immunizations would prevent more than one million cases of gastroenteritis and 33 000 hospitalizations. If the total vaccine cost was US\$ 30 per dose, such a program would have direct medical expenses of approximately US\$ 100 per case of rotavirus prevented but result in a total savings of US\$ 250 million to society each year (244). An additional analysis was made in the

United States based on data collected during a prospective randomized clinical trial that included three oral doses of tetravalent rhesus rotavirus vaccine, serotype 1 rhesus rotavirus vaccine, or placebo (242). These authors concluded that society should be willing to pay between US\$ 11 and US\$ 12 for immunization against rotavirus, as well as an additional amount for the intangible benefits of reduced parental inconvenience or anxiety associated with this illness in infants. An advantage of rotavirus vaccine was that it could be given during already scheduled EPI routine visits, thus incurring fewer additional costs than other vaccines that require extra visits (245). In addition, since the protective efficacy of rotavirus vaccines appeared to be much higher against a severe disease than it is against a mild one, a substantial impact on the direct medical care costs was to be expected (246).

Another issue discussed during the WHO rotavirus workshop in 1997 was the perception that mothers in developing countries would have of the efficacy of the vaccine once it was introduced (226). In some cases, for example, a child may experience as many as 30–50 episodes of diarrhea in the first 5 years of life, with only one or two of these due to rotavirus. This is a situation that is quite different from that of measles immunization, for example, where children are protected against a distinctive, easily recognized disease. Therefore, the impact of rotavirus vaccination will not be so evident to parents, but physicians and other health care workers should see a substantial decline in the number of diarrhea-related clinic visits, hospitalizations, and deaths. Therefore, among the strategies to establish rotavirus vaccination in developing countries should be efforts to correctly alert parents to the importance of the disease (245). This task will be even more difficult given the link between rotavirus vaccines and the risk of developing intussusception. Parents should be made fully aware that the benefits of vaccination will largely outweigh any possible adverse reaction.

Rotavirus vaccine need, demand, supply, and quality

The global market for rotavirus vaccine corresponds approximately to the number of global births annually, about 130 million (245). This suggests the need for a multiplicity of suppliers, as well as long-term planning for supplies of one or more vaccines that are proven effective in developing countries.

The potential for local production of live oral rotavirus vaccine is an issue that should also be considered among strategies for attaining an adequate worldwide supply, while also maintaining quality. Since manufacturing of rotavirus vaccine requires the use of cell cultures, some Latin American countries could adapt their polio production facilities to prepare rotavirus vaccines for human use. It is unlikely, however, that such an adaptation will be possible before polio vaccine needs diminish as a result of progress toward eradication (226).

The prospect of local production of rotavirus vaccines brings a need for such official international bodies as WHO and the United Nations Children's Fund (UNICEF) to advise manufacturers, such as with regulatory guidelines or requirements on the use of appropriate cell substrates (not primary cell cultures), virus seed banks, and standardized vaccine testing assays (247). An initial source of such guidelines could be ones from the United States Food and Drug Administration (248). Since they will be dealing with a live vaccine, it is critical that manufacturers in developing countries obtain all materials used in the production process from high-standard sources that assure they have been tested for all adventitious agents.

WHO and UNICEF have said that the "backbone" of the EPI is the cold chain, that is, the network of refrigerators, freezers, and cold boxes organized by teams of people throughout the world (239). If special handling, storage, and shipment requirements beyond those applied to other routine vaccines are not necessary for ro-

tavirus vaccine, it would be advantageous to countries in Latin America and elsewhere to make use of this established system. Otherwise, introduction of rotavirus vaccine into developing countries would stress the immunization system and hamper implementation of other high-priority vaccine coverage programs.

The intussusception issue and the need to move rotavirus vaccine research in new directions

Given the withdrawal of the RotaShield® vaccine and the ongoing urgent need for an effective rotavirus vaccine in developing countries, many of the recommendations made at the 1997 WHO workshop on rotavirus vaccines were reassessed recently in another WHO meeting, entitled Future Directions for Rotavirus Vaccine Research in Developing Countries (196). Among the issues addressed at that February 2000 meeting were data on the incidence and risk factors for intussusception, as well as attributable risk with current rotavirus vaccine; future trial designs and directions for disease burden studies; regulatory and supply questions; and ethical aspects of rotavirus vaccines.

The ethical issues were controversial and received particular attention. A key consideration is that the risks and benefits of rotavirus vaccination may differ substantially between developed and developing countries (196). For example, each year there may be only 20 to 40 deaths from rotavirus gastroenteritis in the United States but 15 000 to 30 000 in Bangladesh. This contrast raises the question as to whether it would be ethical or moral not to use RRV-TV in Bangladesh or other countries where a child's risk of death from rotavirus is likely to be much greater than the risk of death from vaccine-associated intussusception.

Preliminary data from Latin America also suggest that the potential benefit of RRV-TV vaccine far outweighs the risk of intussusception (196). In Venezuela, the rate of rotavirus hospi-

talization was found to be 158 times the rate of hospitalization for naturally occurring intussusception. A risk-benefit study conducted in Peru indicated that a rotavirus vaccine would prevent 1 440 deaths and 23 000 hospitalizations, as compared to an estimated 78 cases of intussusception that might be related to the vaccine. Although under-reporting may have occurred for some regions in Brazil, official data indicate a rate of hospitalization for intussusception of only 3.5/100 000/ year among children aged less than 1 year.

The participants at the recent WHO rotavirus meeting agreed that, on ethical grounds, clinical trials with RRV-TV should proceed in developing countries, provided that a number of conditions and safeguards are met. Among these would be a favorable risk-benefit ratio, based on evidence; obtaining official ethical approvals and informed consents that are sensitive to local cultures; a willingness by the target community to support the trial; and monitoring of adverse events during the trial.

Although the conduct of further clinical trials with RRV-TV was regarded as ethical, a number of other concerns were raised at the Geneva meeting relating to using the vaccine in developing countries (196). The *availability* of the vaccine is uncertain, even if results of future trials are promising in regards to both efficacy and risk of developing intussusception. Furthermore, problems could be faced as to the *political acceptability* of RRV-TV, particularly given that new candidate rotavirus vaccines will shortly be available for clinical trials. Investigators at possible sites for RRV-TV testing might find it difficult to obtain formal clearances from local authorities because of the intussusception risk identified in the United States.

A set of six key conclusions and recommendations came out of the recent WHO meeting (196). They were:

- The rapid development of new rotavirus vaccine candidates should be encouraged. Trials with such candidate vaccines must assess the

potential risk for intussusception, and they should be conducted in parallel in developed and developing countries.

- Further testing of RRV-TV in developing countries is ethical, given the potential favorable benefit-risk ratio in these settings. Proper management for possible cases of intussusception is strongly advised. These studies should not be undertaken, however, without the assurance that RRV-TV would be available for general use, if results from the trials prove to be favorable.
- The use of a standardized WHO protocol is recommended for disease burden studies in selected developing countries.
- Research activities dealing with both the pathogenesis and epidemiology of intussusception are strongly recommended, particularly epidemiologic studies in countries where clinical trials with new rotavirus vaccines are being planned.
- WHO should provide continuing support to national regulatory authorities in developing countries so that international standards for vaccine regulation are achieved.
- Laboratory surveillance of rotavirus strains is especially needed in Africa and Asia.

GENERAL CONCLUSIONS

The global need for an effective rotavirus vaccine has been made clear from worldwide studies, which indicate that this virus is the major cause of severe dehydrating diarrhea in young children. Although morbidity rates are similar in developed and developing countries, rotaviruses are estimated to cause as many as one million deaths annually among infants and young children under 5 years of age in developing nations.

During the past 15 years considerable progress has been made toward developing a rotavirus vaccine targeted for use in early infancy. The main goal of this vaccine is the prevention of severe dehydrating diarrhea,

rather than protecting children from rotavirus infection or mild illness.

Although several live attenuated oral vaccines have been obtained, the RRV-TV rhesus-human reassortant vaccine was the first licensed for human use. However, the recommendation for use of this vaccine was recently withdrawn in the United States because of the occurrence of intussusception as an adverse event from vaccination.

Available results from several field trials with live oral rotavirus vaccines indicate that efficacy rates of RRV-TV were generally higher in industrialized countries than they were in developing nations, although the recent data from Venezuela are encouraging. In trials in South America, and in general in developing countries, primary vaccine failure may have resulted from high maternal antibody levels and interference from enteroviruses. Secondary vaccine failures may be a consequence of a waning immunity in the presence of a natural challenge with a large infectious dose or unusual rotavirus types not covered by the vaccine.

The withdrawal of recommendation for use of RRV-TV in the United States will very likely make acceptance of this vaccine in other developed countries difficult. Although it is conceivable that benefits from rotavirus vaccination in the developing areas of the world outweigh the risk of intussusception, it is likely that original plans for further studies with RRV-TV in developing countries will be changed substantially.

The safety of RRV-TV has been assessed through field trials around the world, and mild fever after the first vaccine dose appeared to be the only detectable side effect. Intussusception was detected among vaccine recipients but at rates that did not differ significantly from those of placebo recipients. However, the safety of RRV-TV must be reviewed, given the appearance of intussusception following vaccination in the recent large-scale use in the United States.

Studies carried out in India and other developing countries have shown that the burden of rotavirus

disease within the first 3 months of life may be significant. This suggests it may be beneficial to administer the first rotavirus vaccine dose together with BCG, early in life, followed by vaccinations during the subsequent routine immunization visit. At the time of the first dose, however, maternal antibodies may affect immune response. Since naturally occurring intussusception clusters among those 3 to 6 months old, neonatal rotavirus vaccination may limit the risk of children developing this clinical condition when receiving later doses.

It is likely that rotavirus vaccines, like all new vaccines, will cost significantly more than the vaccines included in existing vaccination programs. These costs will represent a major barrier to rotavirus immunization in less-developed areas, where the disease has a major public health impact. To overcome this problem, WHO and other agencies are encouraging research directed at reducing dosage schedules, identifying new methods to fund vaccine purchases, and exploring options for local development and production of vaccines in developing countries.

When rotavirus vaccine is introduced in developing countries, strategies should be applied to alert parents to the importance of the disease. Parents should be particularly aware of the potential benefits of the rotavirus vaccine, while still knowing that intussusception has been identified as a rare adverse event of vaccination. The

impact of rotavirus vaccine will not be so evident to parents as is the case with measles immunization, for example. Nevertheless, physicians and other health care workers will likely note a considerable decline in the number of clinic visits, hospitalizations, and deaths caused by diarrhea.

Prospects for local production of rotavirus vaccine must be considered. Strategies are needed that will lead to a worldwide vaccine supply, while still maintaining quality. This might include adapting polio production facilities to prepare rotavirus vaccine in some Latin American countries. Such an adaptation is not practical, however, until there is more progress toward eradication, and polio vaccine requirements diminish.

In Latin America it would be advantageous if special handling, storage, and shipment requirements for rotavirus vaccine did not go beyond those already established for routine vaccines.

The intussusception issue underscores the need to explore alternative rotavirus candidate vaccines. In addition, it will be important to conduct future trials of new candidate vaccines concurrently in developed and developing countries. The risks of adverse reactions to any vaccine, such as intussusception following administration of RRV-TV, may be quite different in industrialized and developing countries. It is clear that it would have been helpful to have had data regarding risks of

postvaccine intussusception in diverse settings during the recent experience with RRV-TV in the United States. Without these data, compelling arguments for and against use of the vaccine in developing countries were difficult. Testing of new vaccines in parallel in both developed and developing countries might have changed this situation, and such testing in the future would certainly speed introduction of effective vaccines into settings where the benefit will be the greatest. In addition, studies are needed to better understand both the pathogenesis and the epidemiology of intussusception in developed and developing countries.

Finally, studies on disease burden are increasingly important, using standardized protocols. There is a need to develop regional laboratory networks to share expertise and resources, as well as to monitor circulating rotavirus strains. This will be particularly important in Brazil and other countries where a marked strain diversity has been observed.

Acknowledgments. We are most indebted to Prof. Ralph Lainson for his attention in reviewing this manuscript and to Dr. Roger I. Glass for encouragement and helpful suggestions. We also thank John O'Connor, M.S., and Daniele M. de Barros for editorial assistance in the preparation of the manuscript.

REFERENCES

1. Bern C, Martines J, de Zoysa I, Glass RI. The magnitude of the global problem of diarrhoeal disease: a ten-year update. *Bull WHO* 1992;70:705-714.
2. Snyder JD, Merson MH. The magnitude of the global problem of acute diarrhoeal disease: a review of active surveillance data. *Bull WHO* 1982;60:605-613.
3. Thielman NM, Guerrant RL. From Rwanda to Wisconsin: the global relevance of diarrhoeal diseases. *J Med Microbiol* 1996;44:155-156.
4. Black RE, Lopez de Romana G, Brown KH, Bravo N, Balazar OG, Kanashiro HC. Incidence and etiology of infantile diarrhea and major routes of transmission in Huascar, Peru. *Am J Epidemiol* 1989;129:785-799.
5. Lopez de Romana G, Brown KH, Black RE, Kanashiro HC. Longitudinal studies of infectious diseases and physical growth of infants in Huascar, an underprivileged peri-urban community in Lima, Peru. *Am J Epidemiol* 1989;129:769-784.

6. Schorling JB, Wanke CA, Schorling SK, McAuliffe JF, de Souza MA, Guerrant RL. A prospective study of persistent diarrhea among children in urban Brazilian slums. Patterns of occurrence and etiologic agents. *Am J Epidemiol* 1990;132:144-156.
7. Simhon A, Mata L, Vives M, Rivera L, Vargas S, Ramirez G, et al. Low endemicity and low pathogenicity of rotaviruses among rural children in Costa Rica. *J Infect Dis* 1985;152:1134-1142.
8. Barros FC, Victora CG, Vaughan JP, Teixeira AM, Ashworth A. Infant mortality in southern Brazil: a population based study of causes of death. *Arch Dis Child* 1987;62:487-490.
9. Bailey P, Tsui AO, Janowitz B, Dominik R, Araujo L. A study of infant mortality and causes of death in a rural north-east Brazilian community. *J Biosoc Sci* 1990;22:349-363.
10. De Borrero M. Program for diarrheal disease control in Cali, Colombia. *Bull PAHO* 1984;18:86-89.
11. Pan American Health Organization. Mortality due to intestinal infectious diseases in Latin America and the Caribbean, 1965-1990. *Epidemiol Bull* 1991;12(3):1-10.
12. World Health Organization. Diarrhoeal diseases control programme: an overview of the problem in the Americas. *Wkly Epidemiol Rec* 1982;57:353-355.
13. Feachem RG. Interventions for the control of diarrhoeal diseases among young children: supplementary feeding programmes. *Bull WHO* 1983;61:967-979.
14. De Zoysa I, Rea M, Martines J. Why promote breast-feeding in diarrhoeal disease control programmes. *Health Pol Plan* 1991;6:371-379.
15. Blacklow NR, Greenberg HB. Viral gastroenteritis. *N Engl J Med* 1991;325:252-264.
16. Kotloff KL, Wasserman SS, Steciak JY, Tall BD, Losonsky GA, Nair P, et al. Acute diarrhea in Baltimore children attending an outpatient clinic. *Pediatr Infect Dis J* 1988;7:753-759.
17. Bishop RF, Davidson GP, Holmes IH, Ruck BJ. Virus particles in epithelial cells of duodenal mucosa from children with viral gastroenteritis. *Lancet* 1973;2(7841):1281-1283.
18. Cook SM, Glass RI, LeBaron CW, Ho MS. Global seasonality of rotavirus infections. *Bull WHO* 1990;68:171-177.
19. Kapikian AZ, Chanock RM. Rotaviruses. In: Fields BN, Knipe DM, Chanock RM, Hirsch MS, Melnick JL, Monath TP, et al., eds. *Virology*. 3rd. ed. Philadelphia: Lippincott-Raven Publishers; 1996. pp. 1657-1708.
20. United States, Institute of Medicine. The prospects for immunizing against rotavirus. In: IOM, ed. *New vaccine development: establishing priorities*. Volume 2: Diseases of importance in developing countries. Washington, D.C.: National Academy Press; 1986. pp. 308-318.
21. Miller MA, McCann L. Policy analysis of the use of hepatitis B, Haemophilus influenzae type B-, Streptococcus pneumoniae-conjugate and rotavirus vaccines in national immunization schedules. *Health Econ* 2000;9:19-35.
22. De Zoysa I, Feachem RV. Interventions for the control of diarrhoeal diseases among young children: rotavirus and cholera immunization. *Bull WHO* 1985;63:569-583.
23. Bishop RF. Development of candidate rotavirus-vaccines. *Vaccine* 1993;11:247-254.
24. Ludert JE, Gil F, Liprandi F, Esparza J. The structure of the rotavirus inner capsid studied by electron microscopy of chemically disrupted particles. *J Gen Virol* 1986;67:1721-1725.
25. Brown DW, Mathan MM, Mathew M, Martin R, Beards GM, Mathan VI. Rotavirus epidemiology in Vellore, South India: group, subgroup, serotype, and electrophoretotype. *J Clin Microbiol* 1988;26:2410-2414.
26. Matsui SM, Offit PA, Vo PT, Mackow ER, Benfield DA, Shaw RD, et al. Passive protection against rotavirus-induced diarrhea by monoclonal antibodies to the heterotypic neutralization domain of VP7 and the VP8 fragment of VP4. *J Clin Microbiol* 1989;27:780-782.
27. Molineaux PJ. Human immunity to rotavirus. *J Med Microbiol* 1995;43:397-404.
28. Richardson SC, Bishop RF. Homotypic serum antibody responses to rotavirus proteins following primary infection of young children with serotype 1 rotavirus. *J Clin Microbiol* 1990;28:1891-1897.
29. Green KY, Taniguchi K, Mackow ER, Kapikian AZ. Homotypic and heterotypic epitope-specific antibody response in adult and infant rotavirus vaccinees: implications for vaccine development. *J Infect Dis* 1990;161:667-679.
30. Grimwood K, Lund JCS, Coulson BS, Hudson IL, Bishop RF, Bares GL. Comparison of serum and mucosal antibody responses following severe acute rotavirus gastroenteritis in young children. *J Clin Microbiol* 1988;26:732-738.
31. Ward RL, Knowlton DR, Schiff GM, Hoshino Y, Greenberg HB. Relative concentrations of serum neutralizing antibody to VP3 and VP7 proteins in adults infected with a human rotavirus. *J Virol* 1998;62:1543-1549.
32. Prasad BV, Burns JW, Marietta E, Estes MK, Chiu W. Localization of VP4 neutralization sites in rotavirus by three-dimensional cryo-electron microscopy. *Nature* 1990;343:476-479.
33. Yeager M, Dryden KA, Olson NH, Greenberg HB, Baker TS. Three dimensional structure of rhesus rotavirus by cryoelectron microscopy and image reconstruction. *J Cell Biol* 1990;110:2133-2144.
34. Offit PA, Shaw RD, Greenberg HB. Passive protection against rotavirus-induced diarrhea by monoclonal antibodies to surface proteins VP3 and VP7. *J Virol* 1986;58:700-703.
35. Konno T, Suzuki H, Kitaoka S, Sato T, Fukuhara N, Yoshie O, et al. Proteolytic enhancement of human rotavirus infectivity. *Clin Infect Dis* 1993;16:92-97.
36. Hoshino Y, Kapikian AZ. Rotavirus vaccine development for the prevention of severe diarrhea in infants and young children. *Trends Microbiol* 1994;2:242-249.
37. Ball JM, Tian P, Zeng CQ-Y, Morris AP, Estes MK. Age-dependent diarrhea induced by a rotaviral nonstructural glycoprotein. *Science* 1996;272:101-104.
38. Glass RI, Lang DR, Ivanoff BN, Compans W. Introduction: rotavirus-from basic research to a vaccine. *J Infect Dis* 1996 Sep;174 Suppl 1:S1-S2.
39. Greenberg HB, Valdesuso J, van Wyke K, Midthun K, Walsh M, McAuliffe V, et al. Production and preliminary characterization of monoclonal antibodies directed at two surface proteins of rhesus rotavirus. *J Virol* 1983;47:267-275.
40. Estes MK, Cohen J. Rotavirus gene structure and function. *Microbiol Rev* 1989;53:410-449.
41. Gorziglia M, Larralde G, Kapikian AZ, Chanock RM. Antigenic relationships among human rotaviruses as determined by outer capsid protein VP4. *Proc Natl Acad Sci USA* 1990;87:7155-7159.
42. Gentsch JR, Woods PA, Ramachandran M, Das BK, Leite JP, Alfieri A, et al. Review of G and P typing results from a global collection of rotavirus strains: implications for vaccine development. *J Infect Dis* 1996;174 Suppl 1:S30-S36.
43. Gunasena S, Nakagomi O, Isegawa Y, Kaga E, Nakagomi T, Steele AD, et al. Relative frequency of VP4 gene alleles among human rotaviruses recovered over a 10-year period (1982-1991) from Japanese children with diarrhea. *J Clin Microbiol* 1983;31:2195-2197.
44. Steele AD, Garcia D, Sears J, Gerna G, Nakagomi O, Flores J. Distribution of VP4 gene alleles among human rotaviruses by using probes to the hyperdivergent gene of the VP4 gene. *J Clin Microbiol* 1993;31:1735-1740.
45. Ramachandran M, Gentsch JR, Parashar UD, Jin S, Woods PA, Holmes JL, et al. Detection and characterization of novel rotavirus strains in the United States. *J Clin Microbiol* 1998;36:3223-3229.
46. Hung T, Chen G, Wang C, Chou Z, Chao T, Ye W, et al. Rotavirus-like agent in adult non-bacterial diarrhoea in China [letter]. *Lancet* 1983;2(8358):1078-1079.
47. Hung T, Chen G, Wang C, Yao H, Fang Z, Chao T, et al. Waterborne outbreak of rotavirus diarrhoea in adults in China caused by a novel rotavirus. *Lancet* 1984;1(8387):1139-1142.
48. Riepenhoff-Talty M, Gouvea V, Evans MJ, Svensson L, Hoffenberg E, Sokol RJ, et al. Detection of group C rotavirus in infants with extrahepatic biliary atresia. *J Infect Dis* 1996;174:8-15.
49. Mackow ER. Group B and C rotaviruses. In: Blaser MJ, Smith PD, Ravdin JI, Greenberg HB, Guerrant RL, eds. *Infections of the gastrointestinal tract*. New York: Raven Press; 1995. p. 983-1008.
50. LeBaron CW, Furutan NP, Lew JF, Allen JR, Gouvea V, Moe C, et al. Viral agents of gastroenteritis. Public health importance and outbreak management. *MMWR* 1990;39:1-24.

51. Ward RL, Bernstein DI, Young EC, Sherwood JR, Knowlton DR, Schiff GM. Human rotavirus studies in volunteers: determination of infectious dose and serological response to infection. *J Infect Dis* 1986;154: 871-880.
52. Oishi I, Kimura T, Murakami T, Haruki K, Seto Y, Minekawa Y, et al. Serial observations of chronic rotavirus infection in an immunodeficient child. *Microbiol Immunol* 1991;35:953-961.
53. Mavromichalis J, Evans N, McNeish AS, Bryden AS, Davies HA, Flewett TH. Intestinal damage in rotavirus and adenovirus gastroenteritis assessed by d-xylose malabsorption. *Arch Dis Child* 1977;52:589-591.
54. Kerzner B, Kelly MH, Gall DG, Butler DG, Hamilton JR. Transmissible gastroenteritis: sodium transport in the intestinal epithelium during the course of viral enteritis. *Gastroenterology* 1977;72:457-461.
55. Kohler T, Erben U, Wiedersberg H, Bannert N. Histologische Befunde der Dünndarmschleimhaut bei Rotavirusinfektionen im Säuglings- und Kleinkindalter. *Kinderartl Prax* 1990;58:323-327.
56. Lundgren O, Peregrin AT, Persson K, Kordasti S, Uhnoo I, Svensson L. Role of the enteric nervous system in the fluid and electrolyte secretion of rotavirus diarrhea. *Science* 2000;287:491-495.
57. Bartlett AV 3d, Bednarz-Prashad AJ, DuPont HL, Pickering LK. Rotavirus gastroenteritis. *Ann Rev Med* 1987;38:399-415.
58. Bass DM, Greenberg HB. Group A rotaviruses. In: Blaser MJ, Smith PD, Ravdin JJ, Greenberg HB, Guerrant RL, eds. *Infections of the gastrointestinal tract*. New York: Raven Press; 1995. pp. 967-982.
59. Velazquez FR, Calva JJ, Guerrero ML, Mass D, Glass RI, Pickering LK, et al. Cohort study of rotavirus serotype patterns in symptomatic and asymptomatic infections in Mexican children. *Ped Infect Dis J* 1993; 12:54-61.
60. Isolauri E, Juntunen M, Wiren S, Vuorinen P, Koivula T. Intestinal permeability changes in acute gastroenteritis: effects of clinical factors and nutritional management. *J Ped Gastroenterol Nutr* 1989;8: 466-473.
61. Rodriguez WJ, Kim HW, Brandt CD, Schwartz RH, Gardner MK, Jeffries B, et al. Fecal adenoviruses from a longitudinal study of families in metropolitan Washington, D.C.: laboratory, clinical and epidemiologic observations. *J Pediatr* 1985;107: 514-520.
62. Santosham M, Burns B, Nadkarni V, Foster S, Garrett S, Croll L, et al. Oral rehydration therapy for acute diarrhea in ambulatory children in the United States: a double-blind comparison of four different solutions. *Pediatrics* 1985;76:159-166.
63. Riepenhoff-Talty M, Offor E, Klossner K, Kowalski E, Carmody PJ, Ogra PL. Effect of malnutrition on rotavirus infection in mice. *Pediatr Res* 1985;19:1250-1253.
64. Biritwum RB, Isomura S, Yamaguchi H, Toba M, Mingle JA. Seroepidemiological study of rotavirus infection in rural Ghana. *Ann Trop Paediatr* 1984;4:237-240.
65. Huilan S, Zhen LG, Mathan MM, Mathew MM, Olarte J, Espejo R, et al. Etiology of acute diarrhoea among children in developing countries: a multicentre study in five countries. *Bull WHO* 1991;69:549-555.
66. Bernstein DI, Sander DS, Smith VE, Schiff GM, Ward RL. Protection from rotavirus infection: 2-year prospective study. *J Infect Dis* 1991;164:277-283.
67. Cravioto A, Reyes RE, Trujillo F, Uribe F, Navarro A, De La Roca JM, et al. Risk of diarrhoea during the first year of life associated with initial and subsequent colonization by specific enteropathogens. *Am J Epidemiol* 1990;131:886-904.
68. Linhares AC, Gabbay YB, Freitas RB, Travassos da Rosa ES, Mascarenhas JDP, Loureiro ECB. Longitudinal study of rotavirus infections among children from Belém, Brazil. *Epidemiol Infect* 1989;102: 129-144.
69. Koopman JS, Monto AS. The Tecumseh study. XV. Rotavirus infection and pathogenicity. *Am J Epidemiol* 1989;130:750-759.
70. Haffeejee I. Neonatal rotavirus infections. *Rev Infect Dis* 1991;13:957-962.
71. Gusmão RHP, Mascarenhas JDP, Gabbay YB, Lins-Lainson Z, Ramos FLP, Monteiro TAF, et al. Rotaviruses as a cause of nosocomial, infantile diarrhoea in Northern Brazil. *Mem Inst Oswaldo Cruz* 1995;90: 743-749.
72. Pacini DL, Brady MT, Budde CT, Connell MJ, Hamparian VV, Hughes JH. Nosocomial rotaviral diarrhea: pattern of spread on wards in a children's hospital. *J Med Virol* 1987;23:359-366.
73. Rodriguez WJ, Kim HW, Brandt CD, Gardner MK, Parrott RH. Use of electrophoresis of RNA from human rotavirus to establish the identity of strains involved in outbreaks in a tertiary care nursery. *J Infect Dis* 1983; 148:34-40.
74. Black RE, Brown KH, Becker S, Alim AR, Huq I. Longitudinal studies of infectious diseases and physical growth of children in rural Bangladesh II. Incidence of diarrhoea and association with known pathogens. *Am J Epidemiol* 1982;115: 315-324.
75. Pérez-Schael I. The impact of rotavirus disease in Venezuela. *J Infect Dis* 1996; 174 Suppl 1:S19-S21.
76. Rodriguez WJ, Kim HW, Brandt CD, Schwartz RH, Gardner MK, Jeffries B, et al. Longitudinal study of rotavirus infection and gastroenteritis in families served by a pediatric medical practice: clinical and epidemiological observations. *Pediatr Infect Dis J* 1987;6:170-176.
77. Muchnik GR, Grinstein S, Plaza A. Rotavirus infection in children hospitalized for diarrhoea in Argentina. *Ann Trop Paediatr* 1981;1:167-173.
78. Vergara M, Quiroga M, Grenon S, Villalba V, Pegels E, Chade M, et al. Identificación de enteropatógenos en la diarrea de la infancia y un estudio realizado en la ciudad de Posadas, Misiones, República Argentina. *Rev Latinoam Microbiol* 1992;34: 71-75.
79. Coiro JR, De Almeida Neto AJ, Heuser MC, Bendati MM, Vasconcellos VL. Acute enteritis associated with rotavirus presence in Brazilian children: evaluations on prevalence, therapy and age group. *J Diarrhoeal Dis Res* 1985 Jun;3(2):78-83.
80. Houly CAP, Uchoa MMM, Zaidan AME, Gomes-Neto A, de Oliveira FM, Athayde MAG, et al. Electrophoretic study of the genome of human rotavirus from Maceió, Brazil. *Brazilian J Med Biol Res* 1986;19: 33-37.
81. Linhares AC, Monção HC, Gabbay YB, Araujo VLC de, Serruya AC, Loureiro ECB. Acute diarrhoea associated with rotavirus among children living in Belém, Brazil. *Trans R Soc Trop Med Hyg* 1983;77: 384-390.
82. Avendano LF, Calderon A, Macaya J, Prenzel I, Duarte E. Rotavirus viral RNA electrophoresis in hospitalized infants with diarrhea in Santiago, Chile. *Pediatr Res* 1982; 16:29-30.
83. Figueroa G, Araya M, Ibanez S, Clerc N, Brunser O. Enteropathogens associated with acute diarrhea in hospitalized infants. *J Pediatr Gastroenterol Nutr* 1986;5: 226-231.
84. Hieber JP, Shelton S, Nelson JD, Leon J, Mohs E. Comparison of human rotavirus disease in tropical and temperate settings. *Am J Dis Child* 1978;132:853-858.
85. Mata L, Simhon A, Urrutia JJ, Kronmal RA, Fernandez R, Garcia B. Epidemiology of rotaviruses in a cohort of 45 Guatemalan Mayan Indian children observed from birth to the age of three years. *J Infect Dis* 1983; 148:452-461.
86. Suzuki H, Aman Y, Kinebuchi H, Gutierrez VE, Davila A, Lopez J, et al. Rotavirus infection in children with acute gastroenteritis in Ecuador. *Am J Trop Med Hyg* 1981;30:293-294.
87. Pickering LK, Evans DJ Jr, Munoz O, DuPont HL, Coello-Ramirez P, Vollet JJ, et al. Prospective study of enteropathogens in children with diarrhea in Houston and Mexico. *J Pediatr* 1978;93:383-388.
88. Puerto FI, Polanco-Marín GG, Puerto-Solís MR, Ortega-Acosta G, Góngora-Biachi RA. Diarrea infantil aguda por rotavirus en una población pediátrica de Mérida, Yucatán, México. *Bol Med Hosp Infant Mex* 1989;46: 171-174.
89. Grinstein S, Gomez JA, Bercovich JA, Biscotti EL. Epidemiology of rotavirus infection and gastroenteritis in prospectively monitored Argentine families with young children. *Am J Epidemiol* 1989;130:300-308.
90. Araya M, Figueroa G, Espinoza J, Montesinos N, Spencer E, Brunser O. Acute diarrhoeal disease in children under 7 years of age in a peri-urban slum of Santiago, Chile. *J Hyg* 1985;95:57-67.
91. Beards GM, Desselberger U, Flewett TH. Temporal and geographical distribution of human rotavirus serotypes, 1983 to 1988. *J Clin Microbiol* 1989;27:2827-2833.
92. Brussov H, Sidoti J, Barclay D, Sotek J, Dirren H, Freire HB. Prevalence and serotype specificity of rotavirus antibodies in different age groups of Ecuadorian infants. *J Infect Dis* 1990;162:615-620.
93. Gomez J, Estes MK, Matson DO, Bellinzoni R, Alvarez A, Grinstein S. Serotyping of

- human rotaviruses in Argentina by ELISA with monoclonal antibodies. *Arch Virol* 1990;112:249-259.
94. Gonzalez-Losa MR, Puerto-Solis M, Polanco-Marin GG, Peniche-Rodriguez R, Puerto FI. Frecuencia de serotipos G de rotavirus aislados de niños con diarrea en Mérida, Yucatán, México. *Rev Invest Clin* 1994;46:215-219.
 95. Linhares AC, Gabbay YB, Mascarenhas JDP, Freitas RB, Flewett TH, Beards GM. Epidemiology of rotavirus subgroups and serotypes in Belém, Brazil: a three-year study. *Ann Virol (Inst. Pasteur)* 1988;139:89-99.
 96. Ward RL, Clemens JD, Sack DA, Knowlton DR, McNeal MM, Huda N, et al. Culture adaptation and characterization of group A rotaviruses causing diarrheal illnesses in Bangladesh from 1985 to 1986. *J Clin Microbiol* 1991;29:1915-1923.
 97. White L, Garcia D, Boher Y, Blanco M, Pérez M, Romer H, et al. Temporal distribution of human rotavirus serotypes 1, 2, 3 and 4 in Venezuelan children with gastroenteritis during 1979-1989. *J Med Virol* 1991;34:79-84.
 98. Gouvea V, de Castro L, Timenetsky MC, Greenberg H, Santos N. Rotavirus serotype G5 associated with diarrhea in Brazilian children. *J Clin Microbiol* 1994;32:1408-1409.
 99. Leite JP, Alfieri AA, Woods PA, Glass RI, Gentsch JR. Rotavirus G and P types circulating in Brazil: characterization by RT-PCR, probe hybridization, and sequence analysis. *Arch Virol* 1996;141:2365-2374.
 100. Timenetsky MC, Santos N, Gouvea V. Survey of rotavirus G and P types associated with human gastroenteritis in São Paulo, Brazil, from 1986 to 1992. *J Clin Microbiol* 1994;32:2622-2624.
 101. Bishop RF, Barnes GL, Cipriani E, Lund JS. Clinical immunity after neonatal rotavirus infection: a prospective, longitudinal study in young children. *N Engl J Med* 1983;309:72-76.
 102. Ward RL. Mechanisms of protection against rotavirus in humans and mice. *J Infect Dis* 1996;174 Suppl 1:S51-S58.
 103. Hoshino Y, Saif LJ, Sereno MM, Chanock RM, Kapikian AZ. Infection immunity of piglets to either VP3 or VP7 outer capsid protein confers resistance to challenge with a virulent rotavirus bearing the corresponding antigen. *J Virol* 1988;62:744-748.
 104. Ward RL, Kapikian AZ, Goldberg KM, Knowlton DR, Watson MW, Rappaport R. Serum neutralizing-antibody titers compared by plaque reduction and enzyme-linked immunosorbent assay-based neutralization assays. *J Clin Microbiol* 1996;34:983-985.
 105. McNabb PC, Tomasi TB. Host defense mechanisms at mucosal surfaces. *Annu Rev Microbiol* 1981;35:477-496.
 106. Mestecky J, McGhee JR. Immunoglobulin A (IgA): molecular and cellular interactions involved in IgA biosynthesis and immune response. *Adv Immunol* 1987;40:153-245.
 107. Bhan MK, Lew JF, Sazawal S, Das BK, Gentsch JR, Glass RI. Protection conferred by neonatal rotavirus infection against subsequent rotavirus diarrhea. *J Infect Dis* 1993;168:282-287.
 108. Bernstein DI, Smith VE, Sander DS, Pax KA, Schiff GM, Ward RL. Evaluation of WC3 rotavirus vaccine and correlates of protection in healthy infants. *J Infect Dis* 1990;162:1055-1062.
 109. Chiba S, Yokoyama T, Nakata S, Morita Y, Urasawa T, Taniguchi K, et al. Protective effect of naturally acquired homotypic and heterotypic rotavirus antibodies. *Lancet* 1986;2(8504):417-421.
 110. De Champs C, Laveran H, Peigue-Lafeuille H, Chambon M, Demeocq F, Gaulme J, et al. Sequential rotavirus infections: characterization of serotypes and electrophoretotypes. *Res Virol* 1991;142:39-45.
 111. Reves RR, Mohassin MM, Midthun K, Kapikian AZ, Naguib T, Zaqui AM, et al. An observational study of naturally acquired immunity to rotaviral diarrhea in a cohort of 363 Egyptian children. Calculation of risk for second episodes using age-specific person-years of observation. *Am J Epidemiol* 1989;130:981-988.
 112. Velázquez FR, Matson DO, Calva JJ, Guerrero L, Morrow AL, Cartel-Campbell S, et al. Rotavirus infection in infants as protection against subsequent infections. *N Engl J Med* 1996;335:1022-1028.
 113. Arias CF, López S, Mascarenhas JDP, Romero P, Cano P, Gabbay YB, et al. Neutralizing antibody immune response in children with primary and secondary rotavirus infections. *Clin Diagn Lab Immunol* 1994;1:89-94.
 114. Gerna G, Sarasini A, Torsellini N, Torre D, Parea M, Battaglia M. Group- and type-specific serologic response in infants and children with primary rotavirus infections and gastroenteritis caused by a strain of known serotype. *J Infect Dis* 1990;161:1105-1111.
 115. Green KY, Kapikian AZ. Identification of VP7 epitopes associated with protection against human rotavirus illness or shedding in volunteers. *J Virol* 1992;66:548-553.
 116. O'Ryan ML, Matson DO, Estes MK, Pickering LK. Anti-rotavirus G type-specific and isotype-specific antibodies in children with natural rotavirus infections. *J Infect Dis* 1994;169:504-511.
 117. Coulson BS, Grimwood K, Masencic PJ, Lund JS, Mermelstein N, Bishop RF, et al. Comparison of rotavirus immunoglobulin A coproconversion with other indices of rotavirus infection in a longitudinal study in childhood. *J Clin Microbiol* 1990;28:1367-1374.
 118. Clemens JD, Ward RL, Rao MR, Sack DA, Knowlton DR, Van Loon FPL, et al. Seroepidemiologic evaluation of antibodies to rotavirus as correlates of risk of clinically significant rotavirus diarrhea in rural Bangladesh. *J Infect Dis* 1992;165:161-165.
 119. Coulson BS, Grimwood K, Hudson IL, Barnes GL, Bishop RF. Role of coproantibody in clinical protection of children during reinfection with rotavirus. *J Clin Microbiol* 1992;30:1678-1684.
 120. Matson DO, O'Ryan ML, Herrera I, Pickering LK, Estes MK. Fecal antibody responses to symptomatic and asymptomatic rotavirus infections. *J Infect Dis* 1993;167:577-583.
 121. Offit PA, Clark HF. Vaccines for enteric viral pathogens. In: Blaser MJ, Smith PD, Ravdin JJ, Greenberg HB, Guerrant RL, eds. *Infections of the gastrointestinal tract*. New York: Raven Press; 1995. pp. 1471-1478.
 122. Offit PA. Host factors associated with protection against rotavirus disease: the skies are clearing. *J Infect Dis* 1996;174 Suppl 1: S59-S64.
 123. Offit PA, Dudzik KI. Rotavirus-specific cytotoxic T lymphocytes cross-react with target cells infected with different rotavirus serotypes. *J Virol* 1988;62:127-131.
 124. Dhakarul T, Rott L, Greenberg HB. Recovery from chronic rotavirus infection in mice with severe combined immunodeficiency: virus clearance mediated by adoptive transfer of immune CD8+ T lymphocytes. *J Virol* 1990;64:4375-4382.
 125. Franco MA, Feng N, Greenberg HB. Molecular determinants of immunity and pathogenicity of rotavirus infection in the mouse model. *J Infect Dis* 1996;174 Suppl 1: S47-S50.
 126. Ramsey AJ, Ruby J, Ramshaw IA. A case for cytokines as effector molecules in the resolution of virus infection. *Immunol Today* 1993;14:155-157.
 127. Offit PA, Clark HF. Maternal antibody-mediated protection against gastroenteritis due to rotavirus in newborn mice is dependent on both serotype and titer of antibody. *J Infect Dis* 1985;152:1152-1158.
 128. Yolken RH, Losonsky GA, Vonderfecht S, Leister F, Wee SB. Antibody to human rotavirus in cow's milk. *N Engl J Med* 1985;312:605-610.
 129. Zheng BJ, Ma GZ, Tam JSL, Lo SKF, Hon M, Lam BCC, et al. The effects of maternal antibodies on neonatal rotavirus infection. *Pediatr Infect Dis J* 1991;10:865-868.
 130. Yolken RH, Peterson JA, Vonderfecht SL, Fouts ET, Midthun K, Newburg DS. Human milk mucin inhibits rotavirus replication and prevents experimental gastroenteritis. *J Clin Invest* 1992;90:1984-1991.
 131. Clemens JD, Rao M, Ahmed F, Ward R, Huda S, Chakraborty J, et al. Breastfeeding and the risk of life-threatening rotavirus diarrhea: prevention or postponement? *Pediatrics* 1993;92:680-685.
 132. McLean BS, Holmes IH. Effects of antibodies, trypsin and trypsin inhibitors on susceptibility of neonates to rotavirus infection. *J Clin Microbiol* 1981;13:22-29.
 133. Schaller JP, Saif LJ, Cordle CT, Candler E Jr, Winship TR, Smith KL. Prevention of human rotavirus induced diarrhea in gnotobiotic piglets using bovine antibody. *J Infect Dis* 1992;165:623-630.
 134. Glass RI, Gentsch J, Smith JC. Rotavirus vaccine: success by reassortment? *Science* 1994;265:1389-1390.
 135. Snodgrass DR, Wells PW. Rotavirus infection in lambs: studies on passive protection. *Arch Virol* 1976;52:201-205.
 136. Estes MK. Advances in molecular biology: impact on rotavirus vaccine development. *J Infect Dis* 1996;174 Suppl 1:S37-S46.
 137. Mebus CA, White RG, Bass EP, Twiehaus MJ. Immunity to neonatal calf diarrhea

- virus. *J Am Vet Med Assoc* 1973; 163: 880-883.
138. Wyatt RG, Yolken RH, Urrutia JJ, Mata L, Greenberg HB, Chanock RM, et al. Diarrhea associated with rotavirus in rural Guatemala. A longitudinal study of 24 infants and young children. *Am J Trop Med Hyg* 1979;28:325-328.
 139. Clark HF, Borian FE, Bell LM, Modesto K, Gouvea A, Plotkin AS. Protective effect of WC3 vaccine against rotavirus diarrhea in infants during a predominantly serotype 1 rotavirus season. *J Infect Dis* 1988;158: 570-587.
 140. Hoshino Y, Sereno MM, Midthun K, Flores J, Kapikian AZ, Chanock RM. Independent segregation of two antigenic specificities (VP3 and VP7) involved in neutralization of rotavirus infectivity. *Proc Natl Acad Sci USA* 1985;82:8701-8704.
 141. Vesikari T, Isolauri E, Delem A, D'Hondt E, André FE, Zissis G. Immunogenicity and safety of live oral attenuated bovine rotavirus vaccine strain RIT 4237 in adults and young children. *Lancet* 1983;2(8354): 807-811.
 142. Vesikari T, Isolauri E, D'Hondt E, Delem A, André FE, Zissis G. Protection of infants against rotavirus diarrhoea by RIT 4237 attenuated bovine rotavirus strain vaccine. *Lancet* 1984;1(8384):977-981.
 143. Vesikari T, Ruuska T, Delem A, André FE. Neonatal rotavirus vaccination with RIT 4237 bovine rotavirus vaccine: a preliminary report. *Pediatr Infect Dis J* 1987; 6: 164-169.
 144. Vesikari T, Isolauri E, Delem A, D'Hondt E, André FE, Beards GM, et al. Clinical efficacy of the RIT 4237 live attenuated bovine rotavirus vaccine in infants vaccinated before a rotavirus epidemic. *J Pediatr* 1985; 107:189-194.
 145. Hanlon P, Hanlon L, Marsh V, Byass P, Shenton F, Hassan-King M, et al. Trial of an attenuated bovine rotavirus vaccine (RIT 4237) in Gambian infants. *Lancet* 1987; 1(8546): 1342-1345.
 146. De Mol P, Zissis G, Butzler J-P, Mutwewingabo A, Andre FE. Failure of live, attenuated oral rotavirus vaccine. *Lancet* 1986; 2(8498):108.
 147. Santosham M, Letson GW, Wolff M, Reid R, Gahagan S, Adams R, et al. A field study of the safety and efficacy of two candidate rotavirus vaccines in a Native American population. *J Infect Dis* 1991;163:483-487.
 148. Lanata CF, Black RE, del Aguila R, Gil A, Verastegui H, Gerna G, et al. Protection of Peruvian children against rotavirus diarrhea of specific serotypes by one, two, or three doses of the RIT 4237 attenuated bovine rotavirus vaccine. *J Infect Dis* 1989; 159:452-459.
 149. Clark HF, Furukawa T, Bell LM, Offit PA, Perrella PA, Plotkin AS. Immune response of infants and children to low-passage bovine rotavirus (strain WC3). *Amer J Dis Children* 1986;140:350-356.
 150. Clark HF, Offit PA, Ellis RW, Eiden JJ, Krah D, Shaw AR, et al. The development of multivalent bovine rotavirus (strain WC3) reassortant vaccine for infants. *J Infect Dis* 1996;174 Suppl 1:S73-80.
 151. Garbarg-Chenon A, Fontaine J-L, Lasfargues G, Clark HF, Guyot J, Le Moing G, et al. Reactogenicity and immunogenicity of rotavirus WC3 vaccine in 5-12 month old infants. *Res Virol* 1989;140:207-217.
 152. Georges-Courbot MC, Monjes J, Siopathis MR, ROUNGOU JB, Gresenguet G, Bellec Bouquety C, et al. Evaluation of the efficacy of a low passage bovine rotavirus in children in Central Africa. *Res Virol* 1991;142: 405-411.
 153. Stuker G, Oshiro L, Schmidt NH. Antigenic comparisons of two new rotaviruses from rhesus monkeys. *J Clin Microbiol* 1980;11: 202-203.
 154. Hoshino Y, Kapikian AZ, Chanock RM. Selection of cold-adapted mutants of human rotaviruses that exhibit various degrees of growth restriction in vitro. *J Virol* 1994;68: 7598-7602.
 155. Nishikawa K, Fukuhara N, Liprandi N, Green K, Kapikian AZ, Chanock RM, et al. VP4 protein of porcine rotavirus strain OSU expressed by a baculovirus recombinant induces neutralizing antibodies. *Virology* 1989;173:631-637.
 156. Wallace RE, Vasington PJ, Petricciani JC, Hopps HE, Lorenz DE, Kadanka Z. Development of a diploid cell line from fetal rhesus monkey lung for virus vaccine production. *In Vitro* 1973;8:323-332.
 157. Kapikian AZ, Hoshino Y, Chanock RM, Pérez-Schael I. Efficacy of quadrivalent rhesus rotavirus-based human rotavirus vaccine aimed at preventing severe rotavirus diarrhea in infants and young children. *J Infect Dis* 1996;174 Suppl 1:S65-S72.
 158. Kapikian AZ, Vesikari T, Ruuska T, Madore HP, Christy C, Dolin R, et al. An update on the "Jennerian" and modified "Jennerian" approach to vaccination of infants and young children against rotavirus diarrhea. *Adv Exp Med Biol* 1992;327: 59-69.
 159. Pérez-Schael I, González M, Daoud N, Pérez M, Soto I, Garcia D, et al. Reactogenicity and antigenicity of the rhesus rotavirus vaccine in Venezuelan children. *J Infect Dis* 1987;155:334-338.
 160. Lanata CF, Black RE, Flores J, Lazo F, Butron B, Linares A, et al. Immunogenicity, safety and protective efficacy of one dose of the rhesus rotavirus vaccine and serotype 1 and 2 human-rhesus rotavirus reassortants in children from Lima, Peru. *Vaccine* 1996; 14:237-243.
 161. Losonsky GA, Rennels MB, Kapikian AZ, Midthun K, Ferra PJ, Fortier DN, et al. Safety, infectivity, transmissibility and immunogenicity of rhesus rotavirus vaccine (MMU 18006) in infants. *Ped Infect Dis* 1986;5:25-29.
 162. Vesikari T, Ruuska T, Delem A, André FE. Oral rotavirus vaccination in breast-and bottle-fed infants aged 6 to 12 months. *Acta Paediatr Scand* 1986;75:573-578.
 163. Wright PF, Tajima T, Thompson J, Kokubun K, Kapikian A, Edwards K, et al. Evaluation of a candidate rotavirus vaccine (rhesus rotavirus strain) in children. *Pediatrics* 1987;80:473-480.
 164. Bernstein DI, Glass RI, Rodgers G, Davidson BL, Sack DA. Evaluation of rhesus rotavirus monovalent and tetravalent reassortant vaccines in US children. *JAMA* 1995;273:1191-1196.
 165. Christy C, Madore HP, Pichichero ME, Gala C, Pancus P, Vosefski D, et al. Field trial of rhesus rotavirus vaccine in infants. *Pediatr Infect Dis J* 1988;7:645-650.
 166. Lanata CF, Midthun K, Black RE, Butron B, Huapaya A, Penny ME, et al. Safety, immunogenicity, and protective efficacy of one and three doses of the tetravalent rhesus rotavirus vaccine in infants in Lima, Peru. *J Infect Dis* 1996b; 174: 268-275.
 167. Madore HP, Christy C, Pichichero M, Long C, Pincus P, Vosefsky D, et al. Field trial of rhesus rotavirus or human-rhesus rotavirus reassortant vaccine of VP7 serotype 3 or 1 specificity in infants. *J Infect Dis* 1992; 166:235-243.
 168. Gothefors L, Wadell G, Juto P, Taniguchi K, Kapikian AZ, Glass RI. Prolonged efficacy of rhesus rotavirus vaccine in Swedish children. *J Infect Dis* 1989;159:753-757.
 169. Pérez-Schael I, Garcia D, Gonzalez M, Gonzalez R, Daoud N, Pérez M, et al. Prospective study of diarrheal diseases in Venezuelan children to evaluate the efficacy of rhesus rotavirus vaccine. *J Med Virol* 1990; 30:219-229.
 170. Ukae S, Nakata S, Adachi N, Kogawa K, Chiba S. Efficacy of rhesus rotavirus vaccine MMU-18006 against gastroenteritis due to serotype 1 rotavirus. *Vaccine* 1994; 12:933-939.
 171. Clark HF, Borian FE, Plotkin AS. Immune protection of infants against rotavirus gastroenteritis by a serotype 1 reassortant of bovine rotavirus WC3. *J Infect Dis* 1990;161: 1099-1104.
 172. Midthun K, Greenberg HB, Hoshino Y, Kapikian AZ, Wyatt RG, Chanock RM. Reassortant rotaviruses as potential live rotavirus candidate vaccines. *J Virol* 1985;53: 949-954.
 173. Midthun K, Kapikian AZ. Rotavirus vaccines: an overview. *Clin Microbiol Rev* 1996;9:423-434.
 174. Treanor JJ, Clark HF, Pichichero M, Christy C, Gouvea V, Shrager D, et al. Evaluation of the protective efficacy of a serotype 1 bovine-human rotavirus reassortant vaccine in infants. *Pediatr Infect Dis J* 1995;14: 301-397.
 175. Sereno MM, Gorziglia MI. The outer capsid protein VP4 of murine rotavirus Eb represents a tentative new P type. *Virology* 1994; 199:500-504.
 176. Clark HF, White CJ, Offit PA, Stinson D, Eiden J, Weaver S, et al. Preliminary evaluation of safety and efficacy of quadrivalent human-bovine reassortant rotavirus vaccine *Ped Res* 1995;37:127A.
 177. Clements-Mann ML, Makhene MK, Mrukowicz J, Wright PF, Hoshino Y, Midthun K, et al. Safety and immunogenicity of live attenuated human-bovine (UK

- reassortant rotavirus vaccines with VP7-specificity for serotypes 1, 2, 3 or 4 in adults, children and infants. *Vaccine* 1999; 17: 2715–2725.
178. Midthun K, Hoshino Y, Kapikian AZ, Chanock RM. Single gene substitution rotavirus reassortants containing the major neutralization protein (VP7) of human rotavirus serotype 4. *J Clin Microbiol* 1986;24: 822–826.
 179. Vesikari T, Ruuska T, Green K, Flores J, Kapikian AZ. Protective efficacy against serotype 1 rotavirus diarrhea by live oral rhesus-human reassortant rotavirus vaccines with human rotavirus VP7 serotype 1 or 2 specificity. *Pediatr Infect Dis J* 1992;11: 535–542.
 180. Rennels MB, Wasserman SS, Glass RI, Keane V. Comparison of immunogenicity and efficacy of rhesus rotavirus reassortant vaccines in breastfed and nonbreastfed children. *Pediatrics* 1995;96:1132–1136.
 181. Ward RL, Bernstein DL. Lack of correlation between serum rotavirus antibody titers and protection following vaccination with reassortant RRV vaccines. *US Rotavirus Vaccine Efficacy Group. Vaccine* 1995;13: 1226–1232.
 182. Dagan R, Kassis I, Sarov B, Midthun K, Davidson B, Vesikari T, et al. Safety and immunogenicity of oral tetravalent human-rhesus reassortant rotavirus vaccine in neonates. *Pediatr Infect Dis* 1992;11: 991–996.
 183. Flores J, Pérez-Schael I, Blanco M, White L, García D, Vilar M, et al. Comparison of reactogenicity of M37 rotavirus vaccine and rhesus-rotavirus-based quadrivalent vaccine. *Lancet* 1990;336:330–334.
 184. Ing DJ, Glass RI, Woods PA, Simonetti M, Pallansch MA, Wilcox WD, et al. Immunogenicity of tetravalent rhesus rotavirus vaccine administered with buffer and oral poliovirus vaccine. *Am J Dis Child* 1991;145: 892–897.
 185. Pérez-Schael I, Blanco M, Garcia D, White L, Alfonso E, Crespo I, et al. Evaluation of the antigenicity and reactivity of varying formulations of the rhesus rotavirus-based quadrivalent and the M37 rotavirus vaccine candidates. *J Med Virol* 1994;42: 330–337.
 186. Rennels MB, Glass RI, Dennehy PH, Bernstein DL, Pichichero ME, Zito ET, et al. Safety and efficacy of high-dose rhesus-human reassortant rotavirus vaccines—report of the National Multicenter Trial. *United States Rotavirus Vaccine Efficacy Group. Pediatrics* 1996;97:7–13.
 187. Santosham M, Moulton LH, Reid R, Croll J, Weatherholt R, Ward R, et al. Efficacy and safety of high-dose rhesus-human reassortant rotavirus vaccine in Native American populations. *J Pediatr* 1997;131:632–638.
 188. Pichichero ME, Marsocci SM, Francis AB, Green JL, Disney FA, Rennels MB, et al. A comparative evaluation of the safety and immunogenicity of a single dose of unbuffered oral rhesus/human reassortant serotypes 1, 2 and 4 and combined (tetravalent) vaccines in healthy infants. *Vaccine* 1993;11:747–753.
 189. Joensuu J, Koskenniemi E, Pang X-L, Vesikari T. Randomised placebo-controlled trial of rhesus-human reassortant rotavirus vaccine for prevention of severe rotavirus gastroenteritis. *Lancet* 1997;350:1205–1209.
 190. Vesikari T, Joensuu J. Review of rotavirus vaccine trials in Finland. *J Infect Dis* 1996; 174 Suppl 1:S81–S87.
 191. Linhares AC, Gabbay YB, Mascarenhas JDP, de Freitas RB, Oliveira CS, Bellesi N, et al. Immunogenicity, safety and efficacy of rhesus-human, reassortant rotavirus vaccine in Belém, Brazil. *Bull WHO* 1996;74: 491–500.
 192. Linhares AC, Lanata CF, Hausdorff WP, Gabbay YB, Black RE. Reappraisal of the Peruvian and Brazilian lower titer tetravalent rhesus-human reassortant rotavirus vaccine efficacy trials: analysis by severity of diarrhea. *Pediatr Infect Dis J* 1999;18: 1001–1006.
 193. Pérez-Schael I, Guntiñas MJ, Pérez M, Pagone V, Rojas AM, González R, et al. Efficacy of the rhesus rotavirus-based quadrivalent vaccine in young children in Venezuela. *N Engl J Med* 1997; 337: 1181–1187.
 194. United States, Centers for Disease Control and Prevention. Intussusception among recipients of rotavirus vaccine—United States, 1998–1999. *MMWR* 1999;48:577–581.
 195. Committee on Infectious Diseases, 1999–2000. Possible association of intussusception with rotavirus vaccination. *Pediatrics* 1999;104:575.
 196. World Health Organization. Report of the Meeting on Future Directions for Rotavirus Vaccine Research in Developing Countries. Geneva, 9–11 February, 2000. Geneva: WHO; 2000. (Publication WHO/V&B/00.23).
 197. United States, Centers for Disease Control and Prevention. Withdrawal of rotavirus vaccine recommendation. *MMWR* 1999; 282:1007.
 198. Rennels MB, Parashar UD, Holman RC, Le CT, Chang H-G, Glass RI, et al. Lack of apparent association between intussusception and wild or vaccine rotavirus infection. *Ped Infect Dis J* 1998;17:924–925.
 199. Foster RH, Wagstaff AJ. Tetravalent human-rhesus reassortant rotavirus vaccine: a review of its immunogenicity, tolerability and protective efficacy against paediatric rotavirus gastroenteritis. *Biodrugs* 1998;9: 155–178.
 200. Konno T, Suzuki H, Kutsuzawa T, Imai A, Katsushima M, Sakamoto M, et al. Human rotavirus infection in infants and young children with intussusception. *J Med Virol* 1978; 2: 265–269.
 201. Mulcahy DL, Kamath KR, de Silva LM, Hodges S, Carter IW, Cloonan MJ. A two-part study of the aetiological role of rotavirus in intussusception. *J Med Virol* 1982; 9:51–55.
 202. Nicolas JC, Ingrand D, Fortier B, Bricout F. A one-year virological survey of acute intussusception in childhood. *J Med Virol* 1982;9:267–271.
 203. Midthun K, Halsey NA, Jett-Goheen M, Clements ML, Steinhoff M, King JC, et al. Safety and immunogenicity of human rotavirus vaccine strain M37 in adults, children and infants. *J Infect Dis* 1991;164:792–796.
 204. Vesikari T, Ruuska T, Delem A, André FE, Beards GM, Flewett TH. Efficacy of two doses of RIT 4237 bovine rotavirus vaccine for prevention of rotavirus diarrhoea. *Acta Paediatr Scand* 1991;80:173–180.
 205. Bishop RF, Hewstone AS, Davidson GP, Townley RR, Holmes IH, Ruck BJ. An epidemic of diarrhea in human neonates involving a reoviruslike agent and “enteropathogenic” serotypes of *Escherichia coli*. *J Clin Pathol* 1976;29:46.
 206. Bernstein DL, Sack DA, Rothstein E, Reisinger K, Smith VE, O’Sullivan D, et al. Efficacy of live, attenuated, human rotavirus vaccine 89–12 in infants: a randomised placebo-controlled trial. *Lancet* 1999;354: 287–290.
 207. Matsuno S, Murakami S, Takagi M, Hayashi M, Inouye S, Hasegawa A, et al. Cold-adaptation of human rotavirus. *Virus Res* 1987;7:273–280.
 208. Ijaz MK, Sabara MJ, Frenchik PJ, Babiuk LA. Assessment of intestinal damage in rotavirus infected neonatal mice by a D-xylose absorption test. *J Virol Methods* 1987;18: 153–157.
 209. Sheridan JF, Smith CC, Manak MM, Aurelian L. Prevention of rotavirus induced diarrhea in neonatal mice born to dams immunized with empty capsids of simian rotavirus SA11. *J Infect Dis* 1984;149:434–438.
 210. Andrew ME, Boyle DB, Coupar BEH, Whitfield PL, Both GW, Bellamy AR. Vaccinia virus recombinants expressing the SA11 rotavirus VP7 glycoprotein gene induce serotype-specific neutralising antibodies. *J Virol* 1987;61:1054–1060.
 211. Reeves PR, Johnson MA, Holmes IH, Dyall-Smith ML. Expression of rotavirus VP7 antigens in fusions with bacterial proteins. *Res Microbiol* 1990;141:1019–1025.
 212. Conner ME, Matson DO, Estes MK. Rotavirus vaccines and vaccination potential. In: Ramig RF, ed. *Rotaviruses*. Berlin: Springer-Verlag; 1994. pp. 286–337.
 213. Andrew ME, Boyle DB, Coupar BEH, Reddy D, Bellamy AR, Both GW. Vaccinia-rotavirus VP7 recombinants protect mice against rotavirus-induced diarrhoea. *Vaccine* 1992;10:189–191.
 214. Andrew ME, Boyle DB, Whitfield PL, Lockett LJ, Anthony ID, Bellamy AR, et al. The immunogenicity of VP7, a rotavirus antigen resident in the endoplasmic reticulum, is enhanced by cell surface expression. *J Virol* 1990;64:4776–4783.
 215. Conner ME, Zarley CD, Hu B, Parsons S, Drabinsky D, Greiner S, et al. Virus-like particles as rotavirus subunit vaccine. *J Infect Dis* 1996;174 Suppl 1:S88–S92.
 216. Crawford SE, Labbé M, Cohen J, Burroughs MH, Zhou Y, Estes MK. Characterization of virus-like particles produced by the expression of rotavirus capsid proteins in insect cells. *J Virol* 1994;68:5945–5952.
 217. Estes MK, Crawford SE, Penaranda EM, Petrie BL, Burns JW, Chan W-K, et al. Synthesis and immunogenicity of the ro-

- tavirus major capsid antigen using a baculovirus expression system. *J Virol* 1987; 61: 1488-1494.
218. Bloom BR. Vaccines for the Third World. *Nature* 1989;342:115-120.
 219. Both GW, Lockett LJ, Janardhana V, Edwards SJ, Bellamy AR, Graham FL, et al. Protective immunity to rotavirus-induced diarrhoea is passively transferred to newborn mice from naive dams vaccinated with a single dose of a recombinant adenovirus expressing rotavirus VP7sc. *Virology* 1993;193:940-950.
 220. Gorziglia M, Kapikian AZ. Expression of the OSU rotavirus outer capsid protein VP4 by adenovirus recombinant. *J Virol* 1992;66: 4407-4412.
 221. Gunn PR, Sato F, Powell KFH, Bellamy AR, Napier JR, Harding DRK, et al. Rotavirus neutralizing protein VP7: antigenic determinants investigated by sequence analysis and peptide synthesis. *J Virol* 1985;54: 791-797.
 222. Arias CF, Garcia G, López S. Priming for rotavirus neutralizing antibodies by a VP4 protein-derived synthetic peptide. *J Virol* 1989;63:5393-5398.
 223. Borrás-Cuesta F, Petit-Camurdan A, Fedon Y. Engineering of immunogenic peptides by co-linear synthesis of determinants recognized by B and T cells. *Eur J Immunol* 1987;17:1213-1215.
 224. Herrmann JE, Chen SC, Fynan EF, Santoro JC, Greenberg HB, Wang S, et al. Protection against rotavirus infections by DNA vaccination. *J Infect Dis* 1996;174 (Suppl 1): S93-S97.
 225. Webster RG, Fynan EF, Santoro JC, Robinson H. Protection of ferrets against influenza challenge with a DNA vaccine to haemagglutinin. *Vaccine* 1994;12:1495-1498.
 226. World Health Organization, Centers for Disease Control and Prevention, Children's Vaccine Initiative. Report on Consensus Workshop: Rotavirus Vaccines for the Immunization of Children in Developing Countries. Geneva, 9-10 January, 1997. Geneva, Switzerland: WHO; 1997.
 227. Pickering LK, Morrow AL, Herrera I, O'Ryan M, Estes MK, Williams SE, et al. Effect of maternal rotavirus immunization on milk and serum antibody titers. *J Infect Dis* 1995;172:723-728.
 228. Rennels MB. Influence of breast-feeding and oral poliovirus vaccine on the immunogenicity and efficacy of rotavirus vaccines. *J Infect Dis* 1996;174 Suppl 1:S107-S111.
 229. Glass RI, Ing DJ, Stoll BJ, Ing RT. Immune response to rotavirus vaccine among breast-fed and nonbreast-fed children. In: Mestecky J, ed. *Immunology of milk and the neonate*. New York: Plenum Press; 1991. p. 249-253.
 230. Pichichero ME. Effect of breast-feeding on oral rhesus rotavirus vaccine seroconversion: a metaanalysis. *J Infect Dis* 1990;162: 753-755.
 231. Ceyhan M, Kanra G, Seçmeer G, Midthun K, Davidson BL, Zito ET, et al. Take of rhesus-human reassortant rotavirus vaccine in breast-fed infants. *Acta Paediatr* 1993;82:223-227.
 232. Vodopija I, Baklaic Z, Vlatkovic R, Bogaerts H, Delem A, André FE. Combined vaccination with live oral polio vaccine and the bovine rotavirus RIT 4237 strain. *Vaccine* 1996;4:233-236.
 233. Giammanco G, DeGrandi V, Lupo L, Mistretta A, Pignato S, Teuween D, et al. Interference of oral poliovirus vaccine on RIT 4237 oral rotavirus vaccine. *Eur J Epidemiol* 1988;4:233-236.
 234. Ho MS, Floyd RL, Glass RI, Pallansch MA, Jones B, Hamby B, et al. Simultaneous administration of rhesus rotavirus vaccine and oral poliovirus vaccine: immunogenicity and reactogenicity. *Pediatr Infect Dis J* 1989;8:692-696.
 235. Jalil F, Zaman S, Carlsson B, Glass RI, Kapikian AZ, Mellander L, et al. Immunogenicity and reactogenicity of rhesus rotavirus vaccine given in combination with oral or inactivated poliovirus vaccine and diphtheria-tetanus-pertussis vaccine. *Trans R Soc Trop Med Hyg* 1991;85:292-296.
 236. Rennels MB, Ward RL, Mack ME, Zito ET. Concurrent oral poliovirus and rhesus-human reassortant rotavirus vaccination effects on immune responses to both vaccines and on efficacy of rotavirus vaccines. The US Rotavirus Vaccine Efficacy Group. *J Infect Dis* 1996;173:306-313.
 237. Rennels MB. Influence of breast-feeding and oral poliovirus vaccine on the immunogenicity and efficacy of rotavirus vaccines. *J Infect Dis* 1996; 174(Suppl 1): S107-S111.
 238. Migasena S, Simasathien S, Samakoses R, Pitisuttitham P, Sangaroon P, van Steenis G, et al. Simultaneous administration of oral rhesus-human reassortant tetravalent (RRV-TV) rotavirus vaccine and oral poliovirus vaccine (OPV) in Thai infants. *Vaccine* 1995; 13:168-174.
 239. World Health Organization Collaborative Study Group on Oral Poliovirus Vaccine. Factors affecting the immunogenicity of oral poliovirus vaccine: a prospective evaluation in Brazil and Gambia. *J Infect Dis* 1995;171:1097-1106.
 240. World Health Organization, United Nations Children's Fund. State of the world's vaccines and immunization. Geneva, Switzerland: WHO; 1996. (Publication WHO/GPV/96.04).
 241. Clemens J, Brenner R, Rao M, Tafari N, Lowe C. Evaluating new vaccines for developing countries. Efficacy or effectiveness. *JAMA* 1996;275:390-397.
 242. Griffiths RI, Anderson GF, Powe NR, Oliveras E, Herberths RJ, Grant CC, et al. Economic impact of immunization against rotavirus gastroenteritis. *Arch Pediatr Adolesc Med* 1995;149:407-414.
 243. Smith JC, Haddix AC, Teutsch SM, Glass RI. Cost-effectiveness analysis of a rotavirus immunization program for the United States. *Pediatrics* 1995;96:609-615.
 244. Tucker AW, Haddix AC, Bresee JS, Holman RC, Parashar UD, Glass RI. Cost-effectiveness analysis of a rotavirus immunization program for the United States. *JAMA* 1998; 279:1371-1376.
 245. Bresee JS, Glass RI, Ivanoff B, Gentsch JR. Current status and future priorities for rotavirus vaccine development, evaluation and implementation in developing countries. *Vaccine* 1999;17:2207-2222.
 246. Orenstein WA, Hadler S, Kuritsky JN, Bernier RH. Rotavirus vaccines—from licensure to disease reduction. *J Infect Dis* 1996; 174 (Suppl 1): S118-S124.
 247. Henchal LS, Midthun K, Goldenthal KL. Selected regulatory and scientific topics for candidate rotavirus vaccine development. *J Infect Dis* 1996;174 (Suppl 1):S112-S117.
 248. United States, Department of Health and Human Services. Points to consider in the manufacture and testing of monoclonal antibody products for human use. *Fed Reg* 1994;59:39571-39572.

Original manuscript received 12 March 1999 and accepted for publication 21 August 1999; revised accepted version received 22 September 2000.

Vacunas y vacunación contra rotavirus en América Latina

RESUMEN

En el mundo, los rotavirus son responsables de más 125 millones de casos de gastroenteritis infantil y de cerca de 1 millón de muertes al año, especialmente en los países en desarrollo. En comparación con otras medidas de control, la vacunación cuenta con mayores probabilidades de tener un impacto significativo en la incidencia de la enfermedad por rotavirus. La máxima incidencia de la diarrea por rotavirus ocurre entre los 6 y los 24 meses de edad. Sin embargo, en los países en desarrollo no son raros los casos en menores de 6 meses. Los serotipos G1 a G4 son responsables de la mayoría de los casos, pero hay datos que indican que en Brasil el tipo G5 está adquiriendo mayor importancia epidemiológica. Durante la infección natural por rotavirus se inducen respuestas inmunitarias tanto homotípicas como heterotípicas y la respuesta inmunitaria en la superficie de la mucosa intestinal constituye probablemente el factor que mejor predice la inmunidad clínica.

Con el objetivo principal de proteger a los niños frente a la diarrea con deshidratación potencialmente mortal, se han probado varios abordajes en el desarrollo de vacunas contra los rotavirus. En los Estados Unidos de América (EUA) se aprobó y comercializó una vacuna antirrotavirus tetravalente recombinante de virus humanos y de *Macaca mulatta* (RRV-TV), pero posteriormente se retiró del mercado.

En varios estudios se ha observado que la eficacia de la vacuna RRV-TV es mayor en los países desarrollados que en los países en desarrollo. En dos países de América Latina (Brasil y Perú) se han realizado estudios de campo con preparaciones de RRV-TV que contenían 4×10^4 unidades formadoras de placa (UFP) y se registraron tasas de eficacia protectora frente a todas las diarreas por rotavirus que oscilaron entre 18 y 35%. En otro estudio realizado en Venezuela con mayores dosis de RRV-TV (4×10^5 UFP/dosis), se obtuvo una tasa de eficacia de 48% frente a todas las diarreas por rotavirus y de 88% frente a las diarreas graves. Parece ser que la lactancia materna no interfiere con la eficacia de la RRV-TV si se administran tres dosis de la vacuna. Del mismo modo, la posible interferencia de la vacuna oral contra la poliomielitis con la vacuna contra los rotavirus puede ser contrarrestada si se administran tres dosis de esta última o se utilizan formulaciones con títulos elevados. Sin embargo, los enterovirus silvestres pueden conducir al fracaso de la vacunación primaria contra los rotavirus en los países en desarrollo. Estudios realizados en Perú con la vacuna RRV-TV han mostrado una tendencia a la obtención de mayores tasas de eficacia de la vacuna frente a los episodios diarreicos causados únicamente por rotavirus ("puros").

Los análisis económicos realizados en los EE.UU. indican que una vacuna que cueste menos de 9 dólares estadounidenses por dosis podría proporcionar ahorros netos en los costes médicos. Sin embargo, hasta la fecha no se han realizado estudios de coste-beneficio en los países en desarrollo. En el futuro, es posible que algunos países de América Latina adapten sus instalaciones de producción de vacunas antipoliomielíticas a la preparación de vacunas contra los rotavirus para uso humano.

Un año después de que la RRV-TV fuera aprobada en los EE.UU. para la vacunación de lactantes, la ocurrencia de casos de intususcepción como reacción adversa a la vacuna condujo a su retirada del mercado. En este artículo se analizan las implicaciones de esta medida, en especial en América Latina, entre ellas la necesidad de investigar vacunas alternativas contra los rotavirus, particularmente mediante la realización de ensayos clínicos paralelos en los países desarrollados y en desarrollo.
